

9. VENTILÁTOROK ÜZEMELTETÉSE 2.

9.1. Soros és párhuzamos kapcsolás

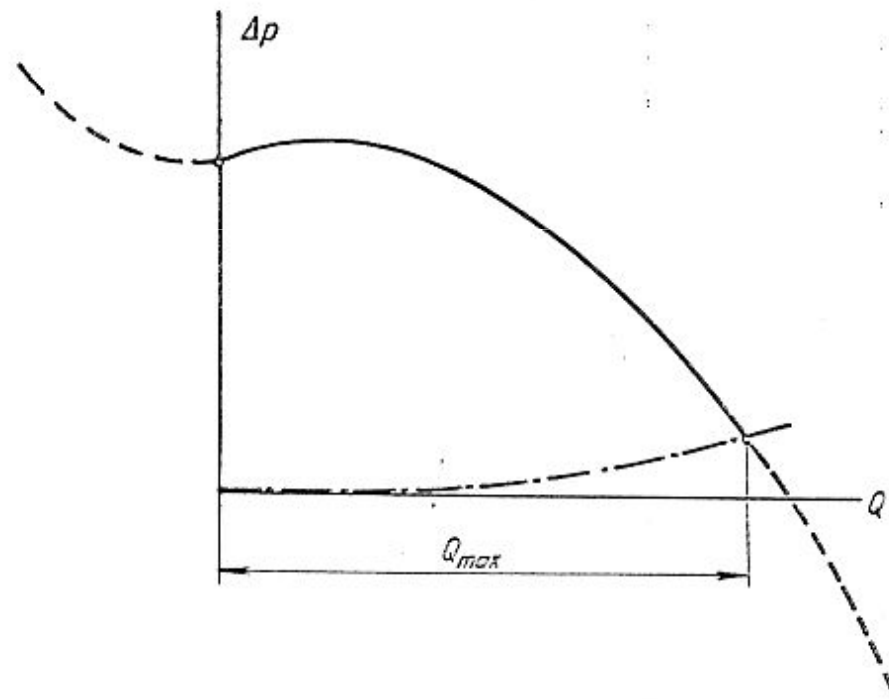

9.1. ábra. „Teljes” ventilátor-jelleggörbe [2]

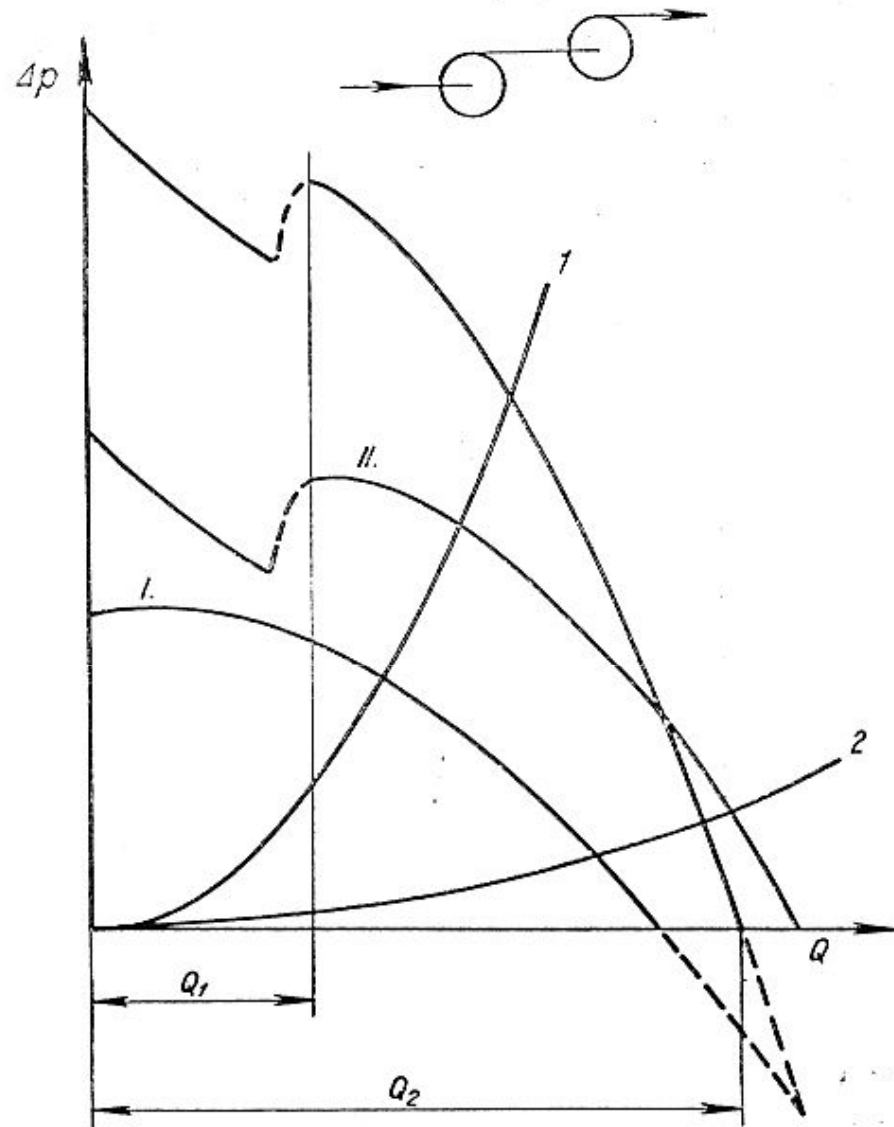

9.2. ábra. Ventilátorok sorbakapcsolása [2]

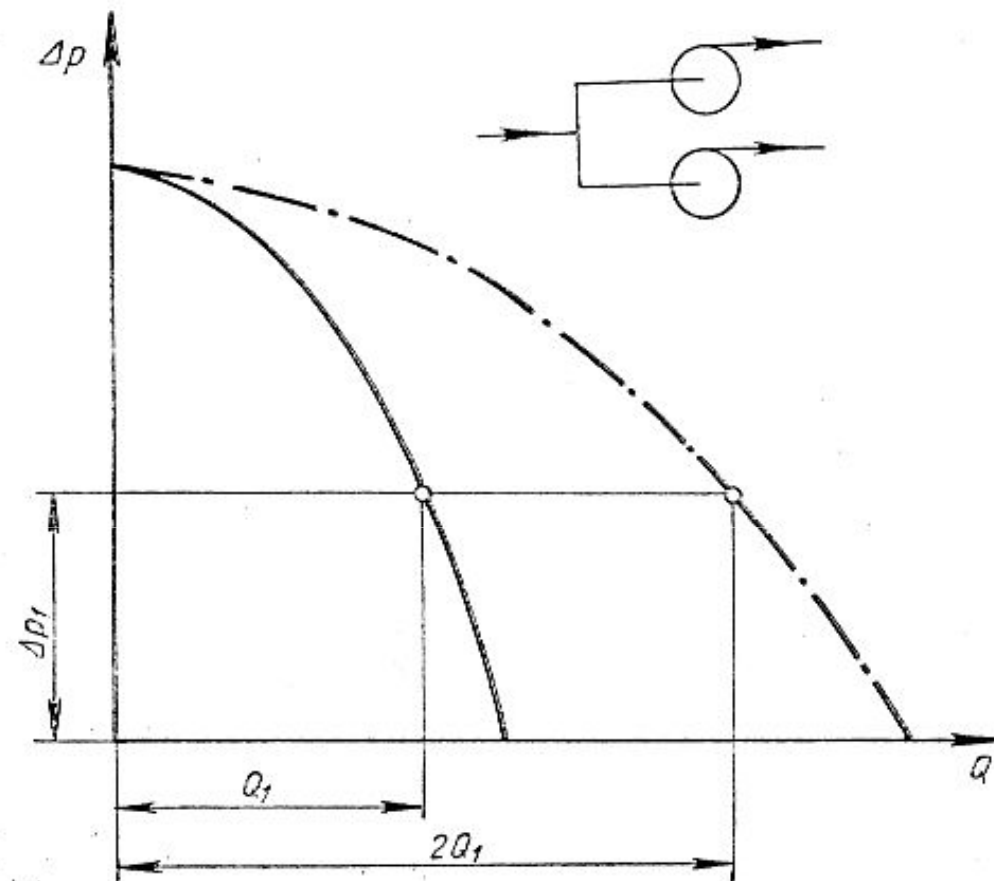

9.3. ábra. Azonos típusú ventilátorok párhuzamos kapcsolása [2]

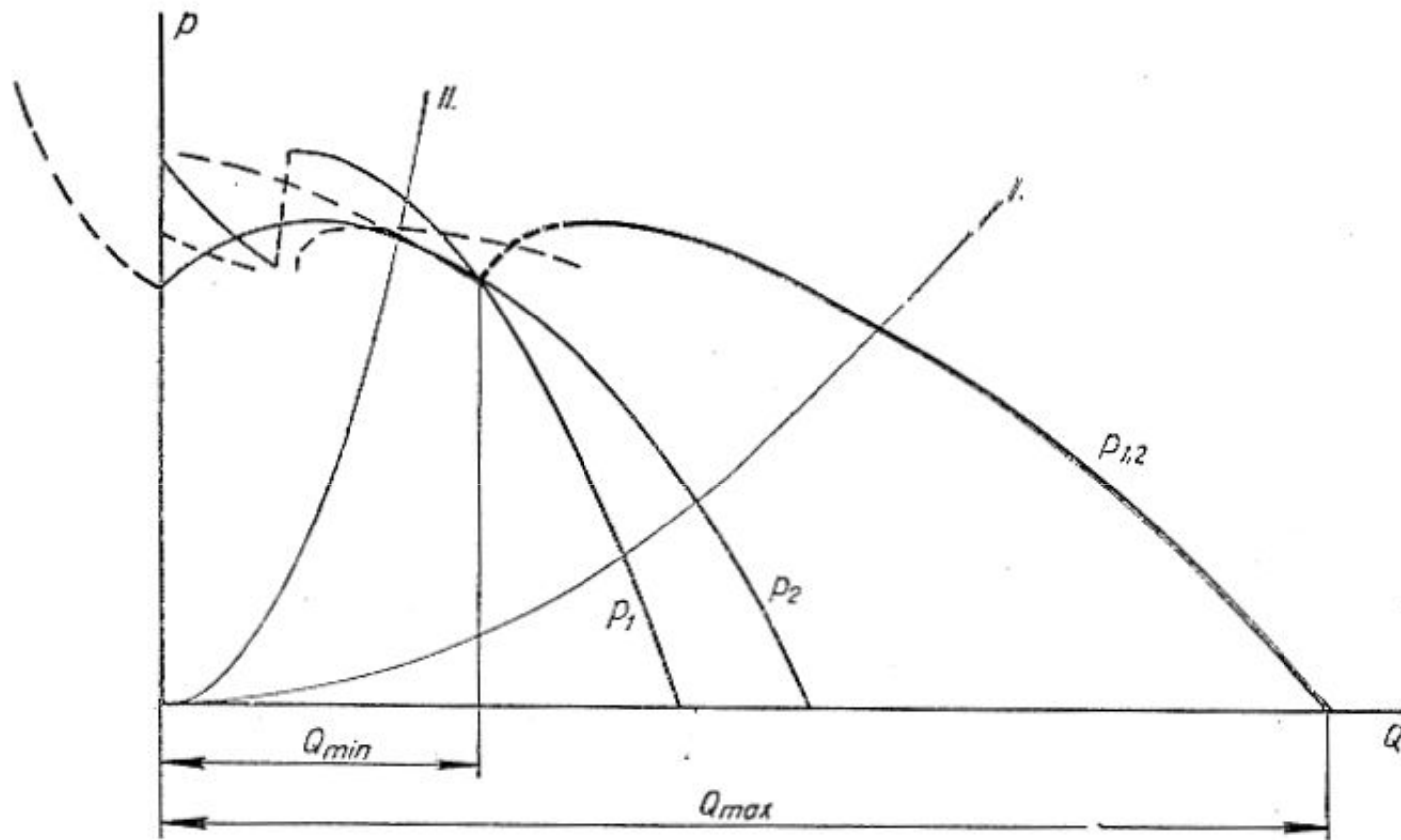

9.4. ábra. Különböző típusú ventilátorok párhuzamos kapcsolása [2]

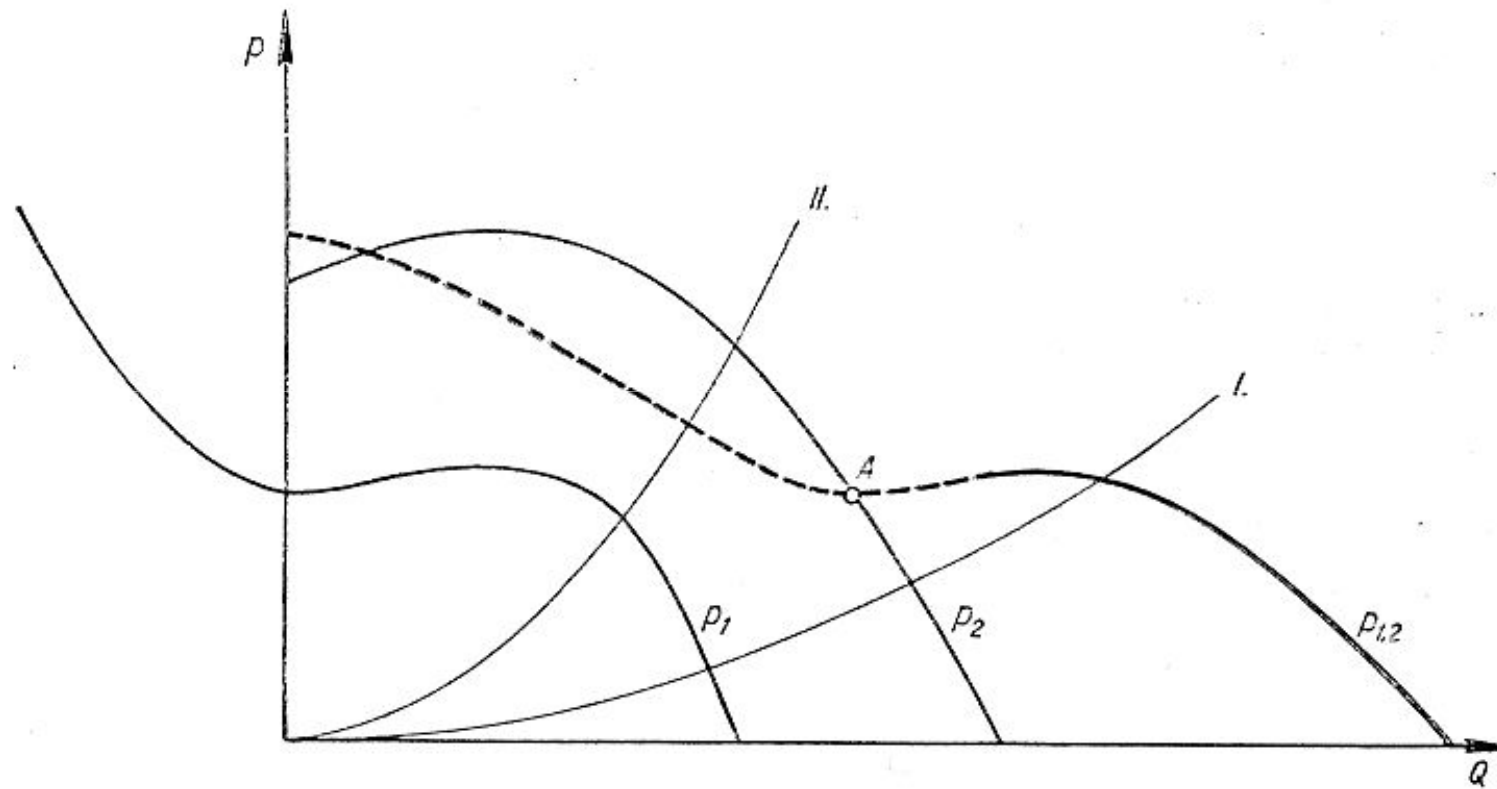

9.5. ábra. Visszafűvés párhuzamos kapcsolt gépeknél [2]

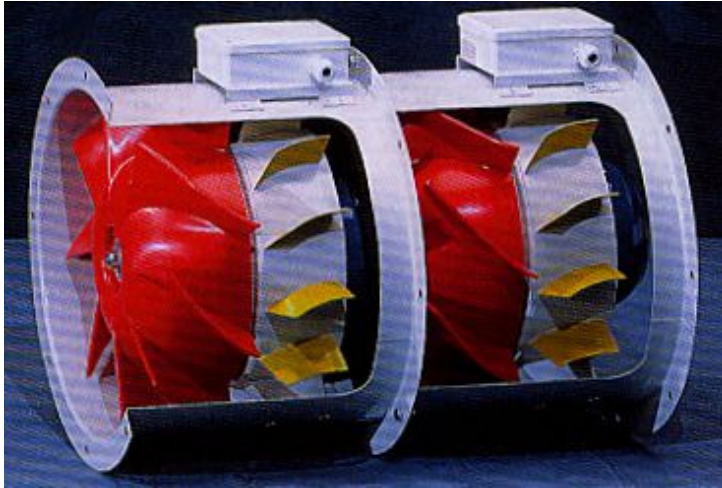

HELIOS TwinVent Z-VAR



HELIOS TwinVent P-VAR

9.2. A munkapont szándékolt változtatása

9.2.1. Fojtás

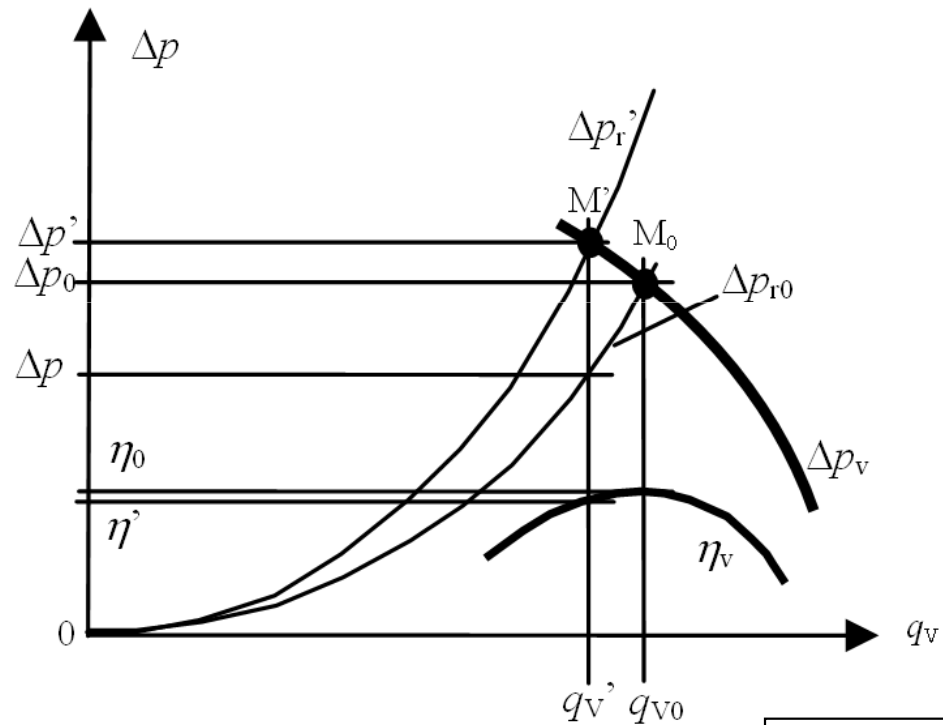

$$\eta_g = \frac{P_{\text{hasznos}}}{P_{\text{befektetett}}}$$

$$P_{\text{hasznos}} = q_v' \Delta p$$

$$P_{\text{befektetett}} = \frac{q_v' \Delta p'}{\eta}$$

$$\eta_{g \text{ fojtás}} = \eta \frac{\Delta p}{\Delta p'}, \quad \eta < \eta_0, \quad \Delta p \ll \Delta p'$$

9.2.2. Megkerülő vezeték (bypass)

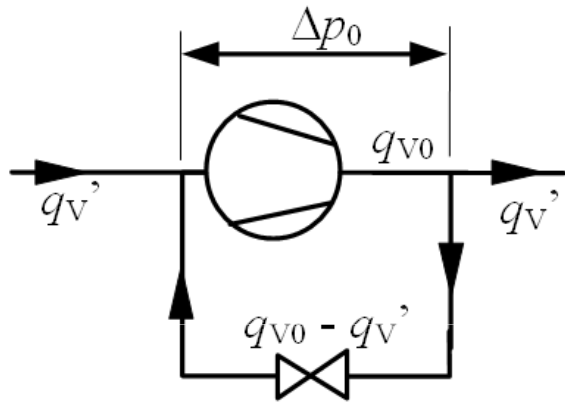

$$\eta_{g \text{ bypass}} = \frac{q_{V'} \Delta p_0}{q_{V0} \Delta p_0 / \eta_0}$$

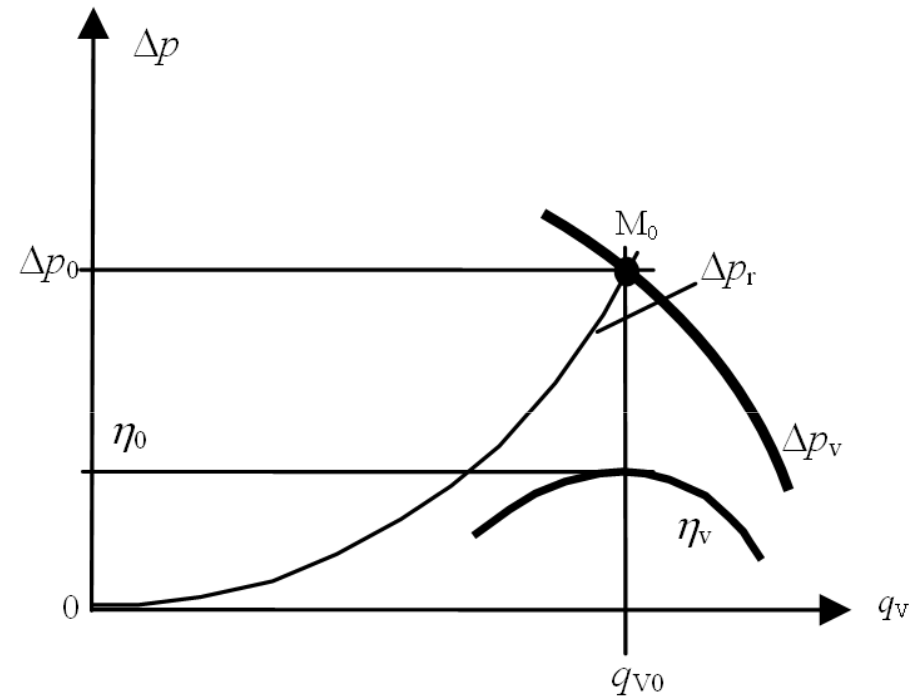

$$\eta_{g \text{ bypass}} = \eta_0 \frac{q_{V'}}{q_{V0}}, \quad \eta_0 = \eta_{\max}, \quad q_{V'} < q_{V0}$$

9.2.3. Fordulatszám-változtatás

Feszültség-leosztás

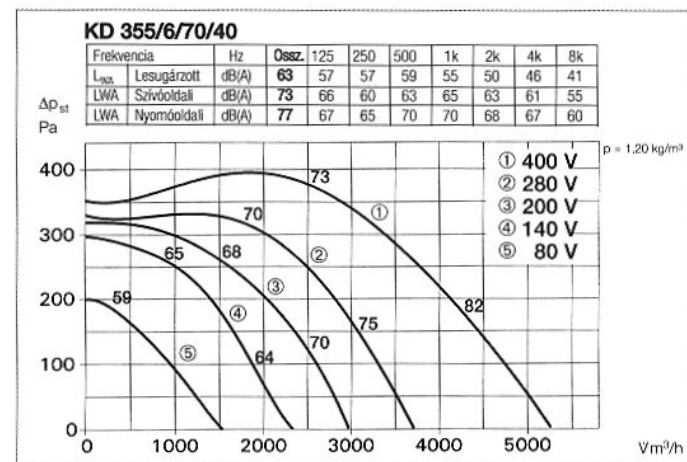
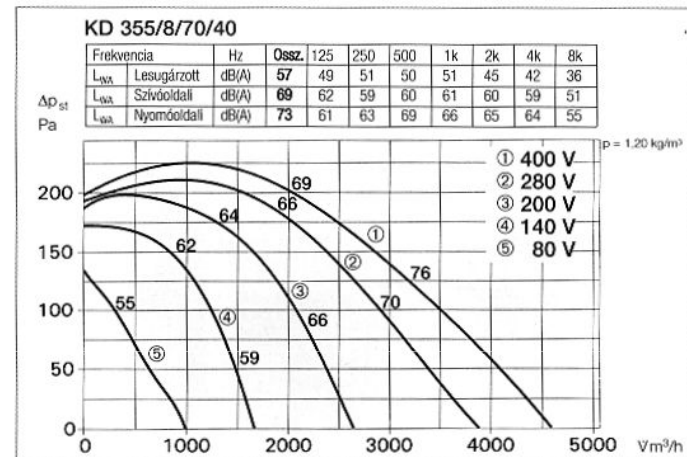
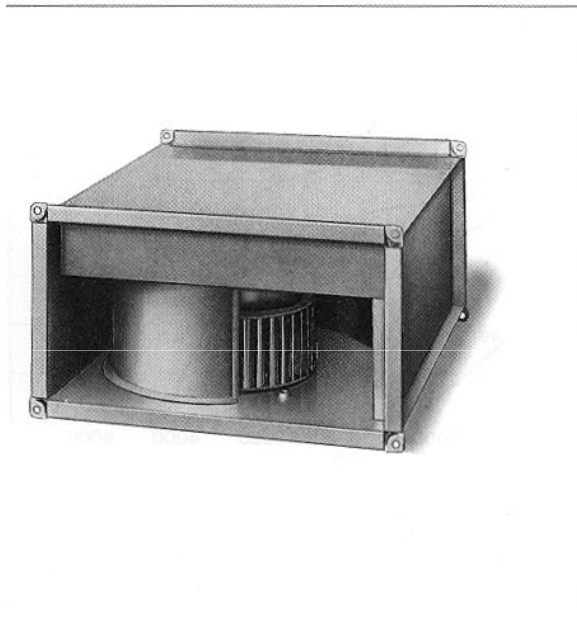

Aszinkron motor póluspár-számának változtatása



Entrauchungs-Axialventilatoren B AVD, 300 °C/60 Min. 1250 mm c

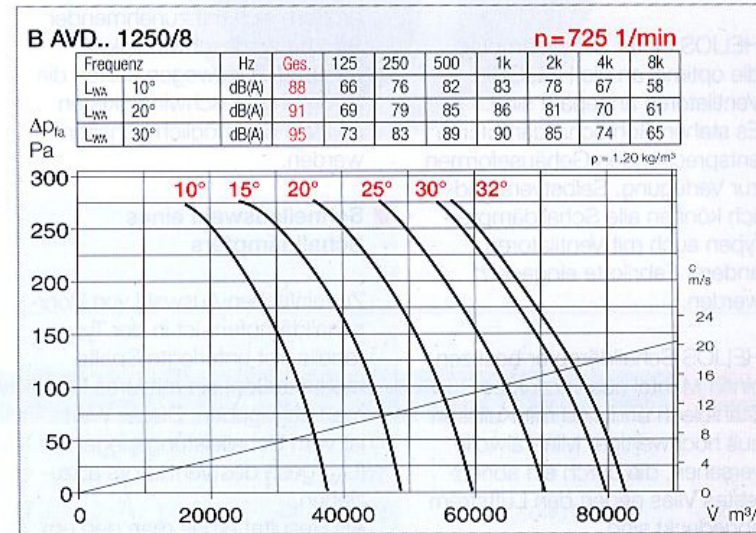
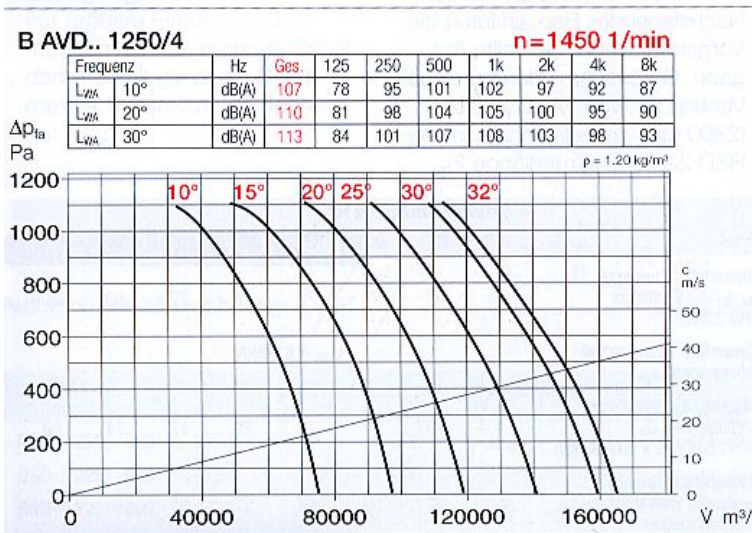
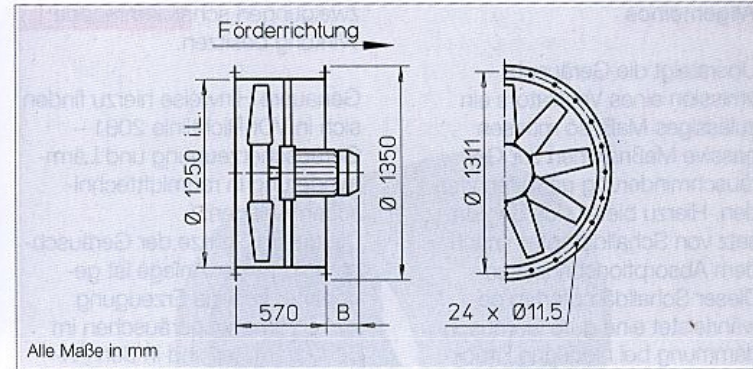
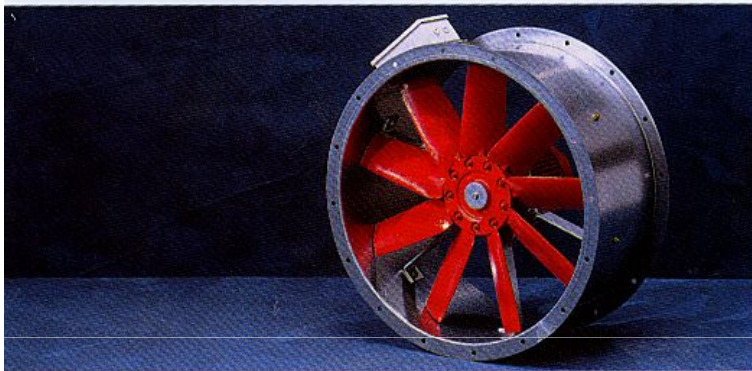

Frekvenciaváltó

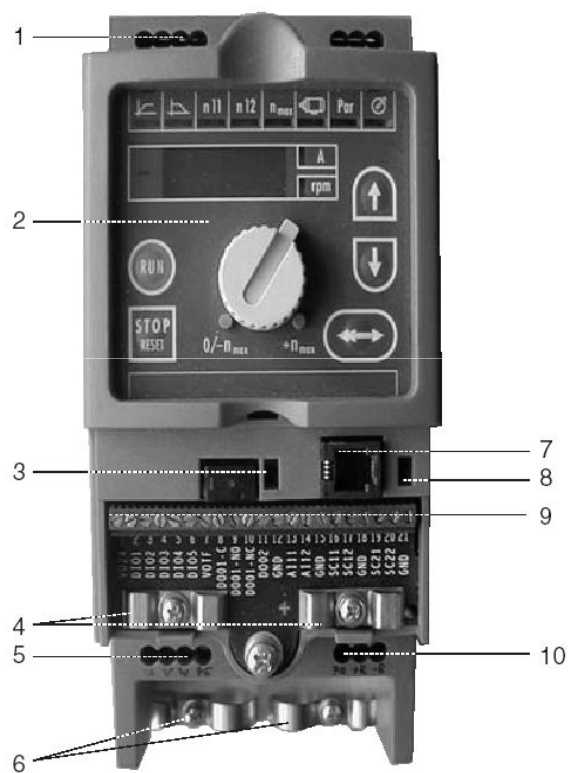

MOVITRAC 07 frekvenciaváltó

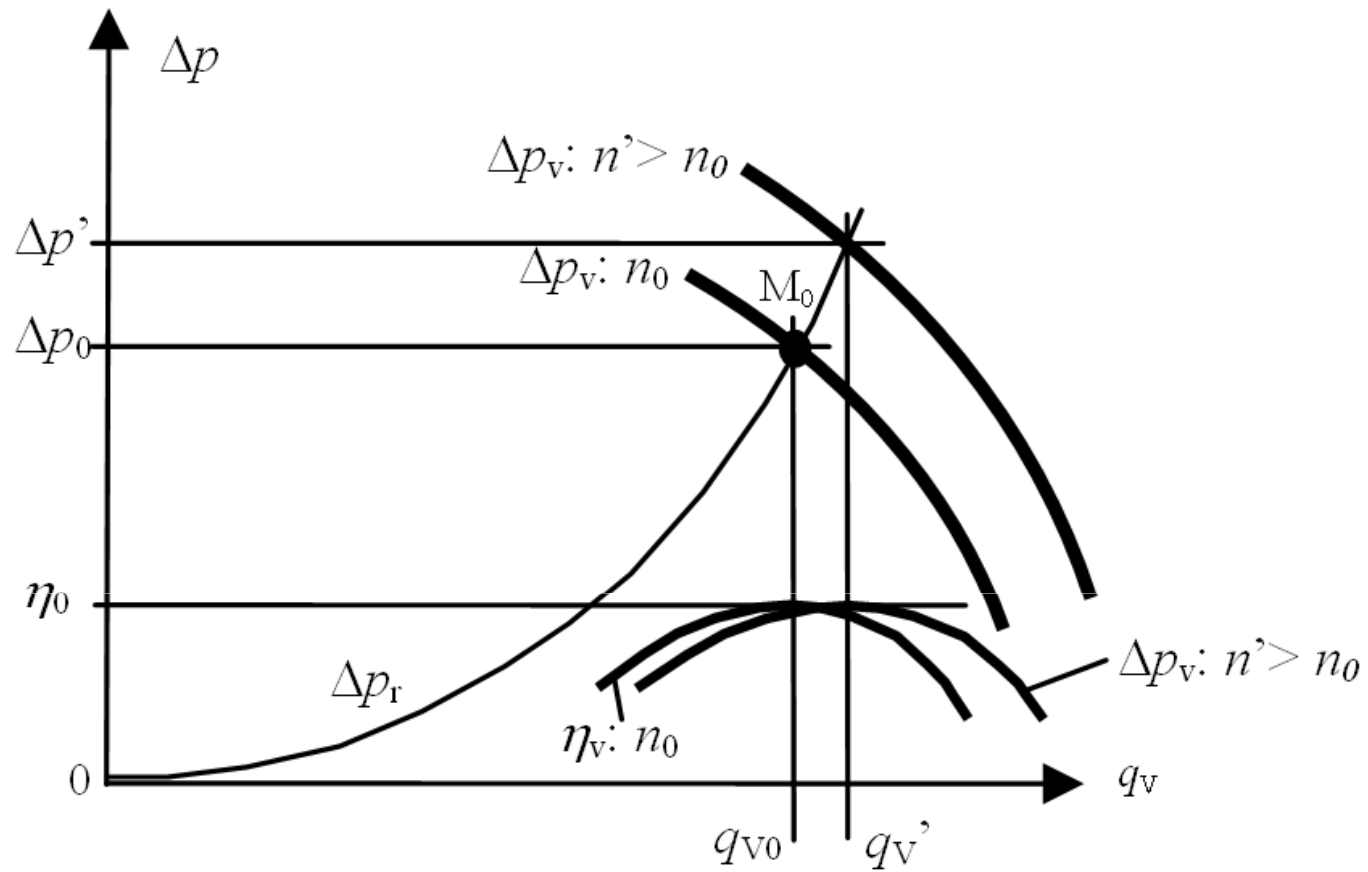

$$\eta_{gn} = \frac{q_v' \Delta p'}{q_v' \Delta p' / \eta_0}$$

$$\eta_{gn} = \eta_0, \quad \eta_0 = \eta_{\max}$$

9.2.4. Az előperdület változtatása

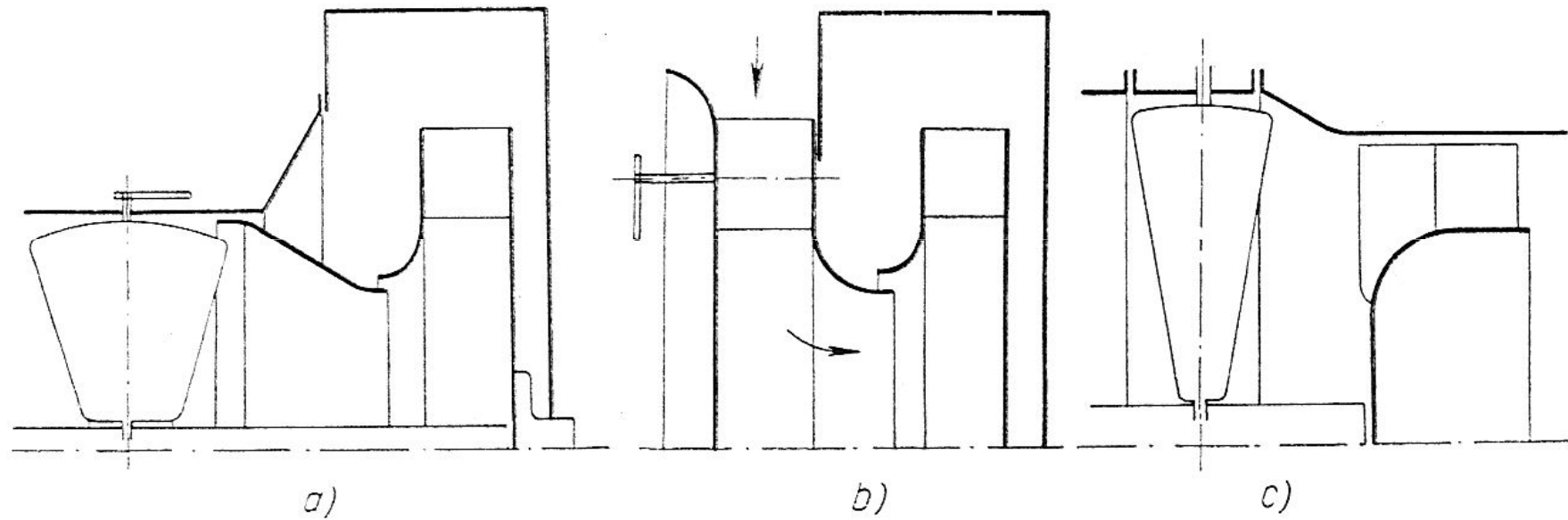

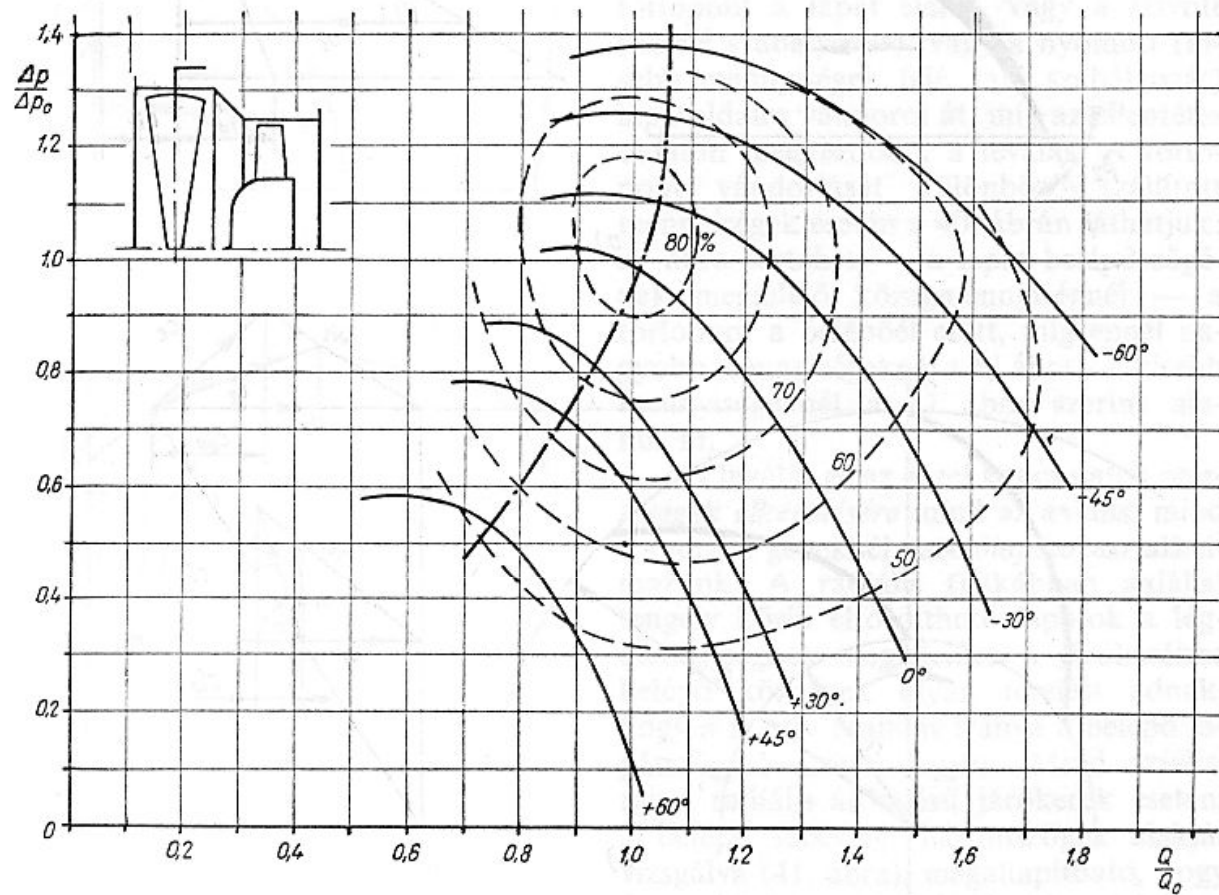

$\pm 20^\circ$:

$$\eta_{g \text{ perd}} \approx \eta_0, \quad \eta_0 = \eta_{\max}$$

9.2.5. A lapátszög változtatása

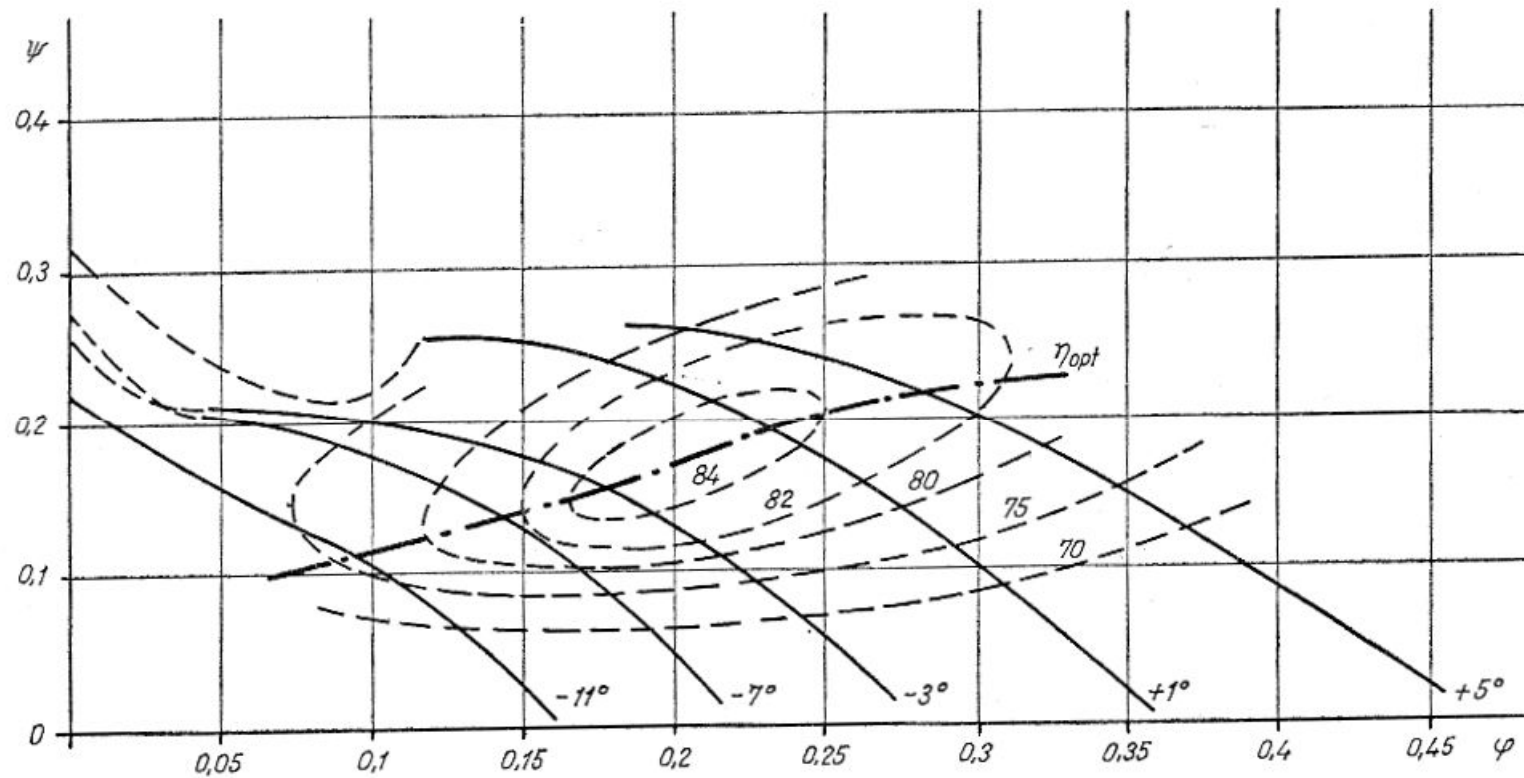

$\pm 10^\circ$:

$$\eta_{g \text{ lapátszög}} \approx \eta_0, \quad \eta_0 = \eta_{\max}$$

9.3. Különleges ventilátorok

-Normális üzemi körülmények

- Különleges üzemi körülmények

- Szennyezett anyag szállítása
- Hőterhelés
- Alacsony hőmérsékletek

9.3.1. Szennyezett anyag szállítása

A/ Szilárd szennyezők

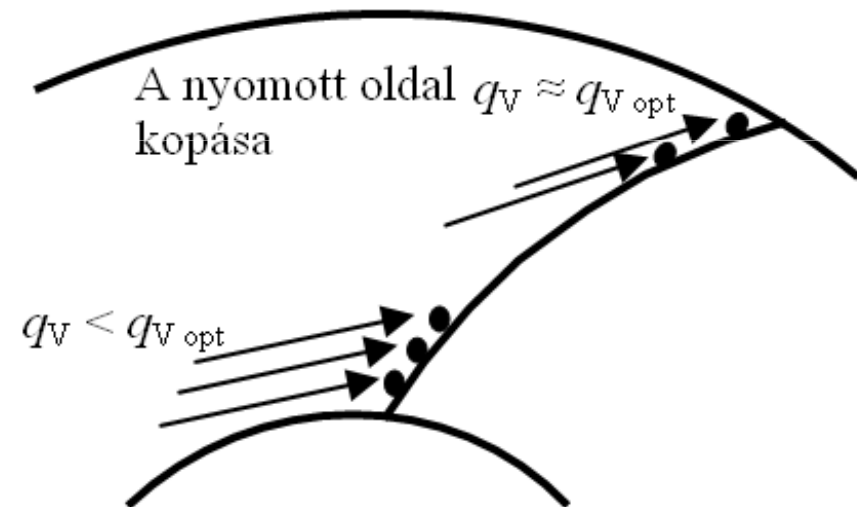
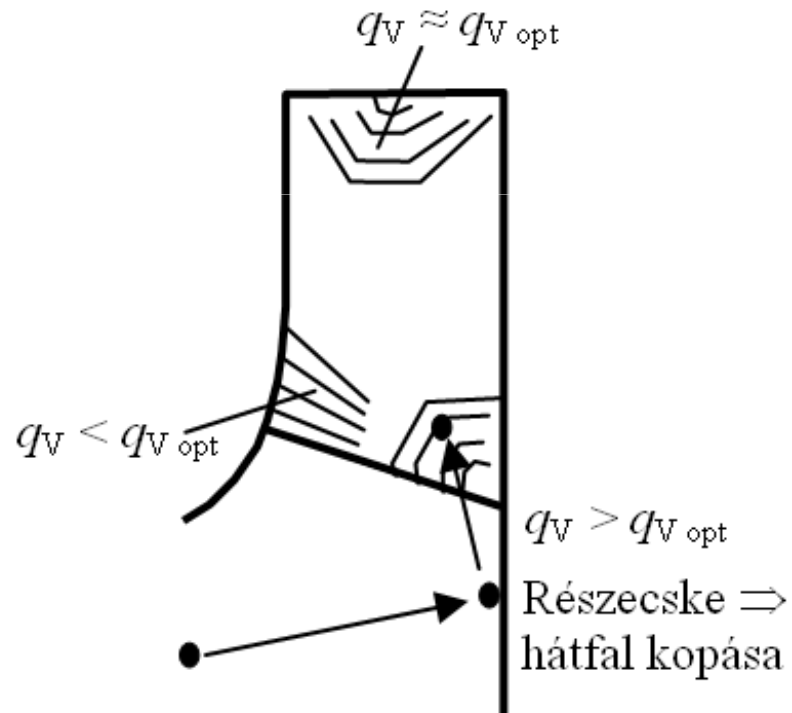

B/ Gáznemű szennyezők





9.4. Ventilátorok zaja

9.4.1. A zaj forrásai

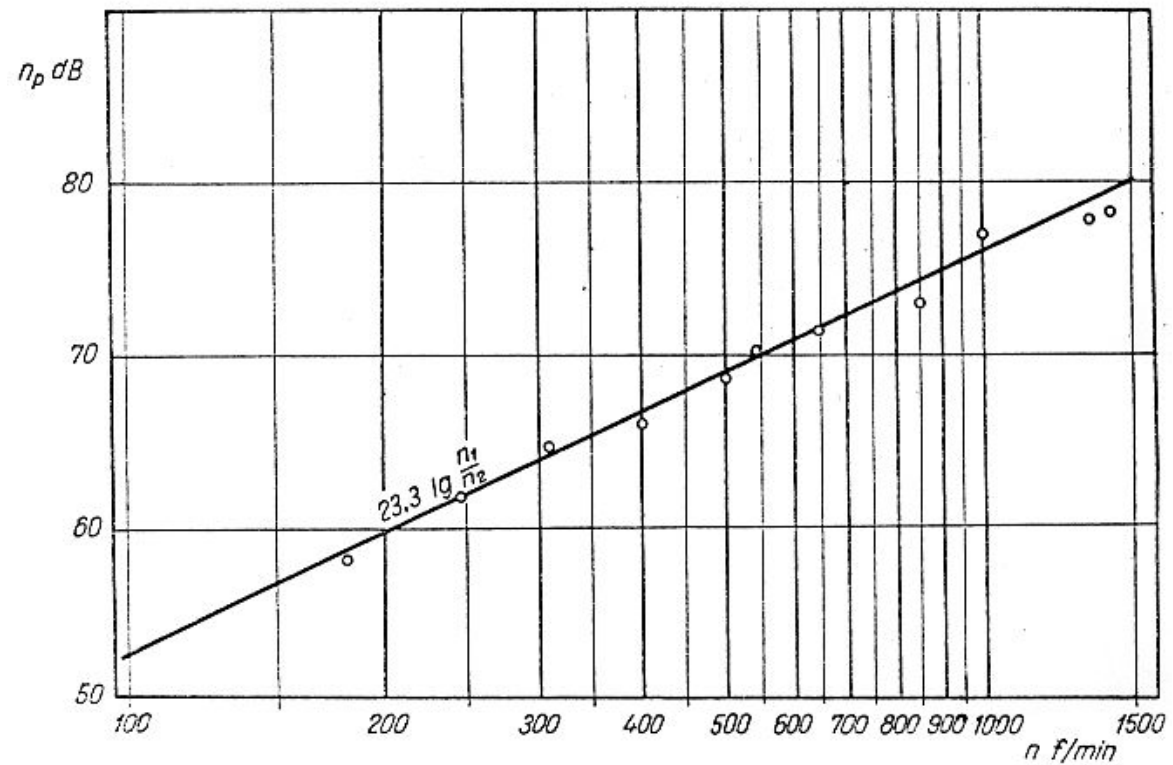
a) Mechanikai zaj

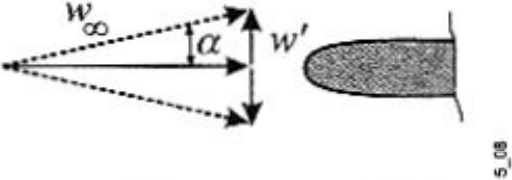
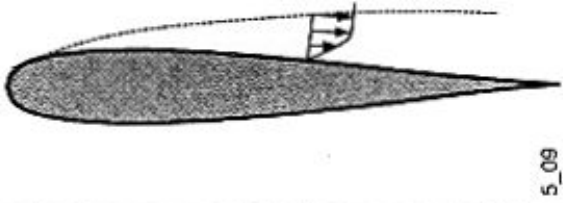

b) Örvényzaj

Mechanismus	
Turbulente Zu- strömung	 <p>5_08</p>
Turbulente Grenzschicht	 <p>5_09</p>
Wirbelablö- sung	 <p>5_10</p>

$$P_{th} \sim v^4 \overline{w'^2} \ell^2$$

$$P_{hz} \sim v^6 \ell^2$$

$$P_{nyom} \sim v^6 Re^{-0.4} \ell^2$$

$$Re = v \ell / \nu$$

c) Forgási zaj

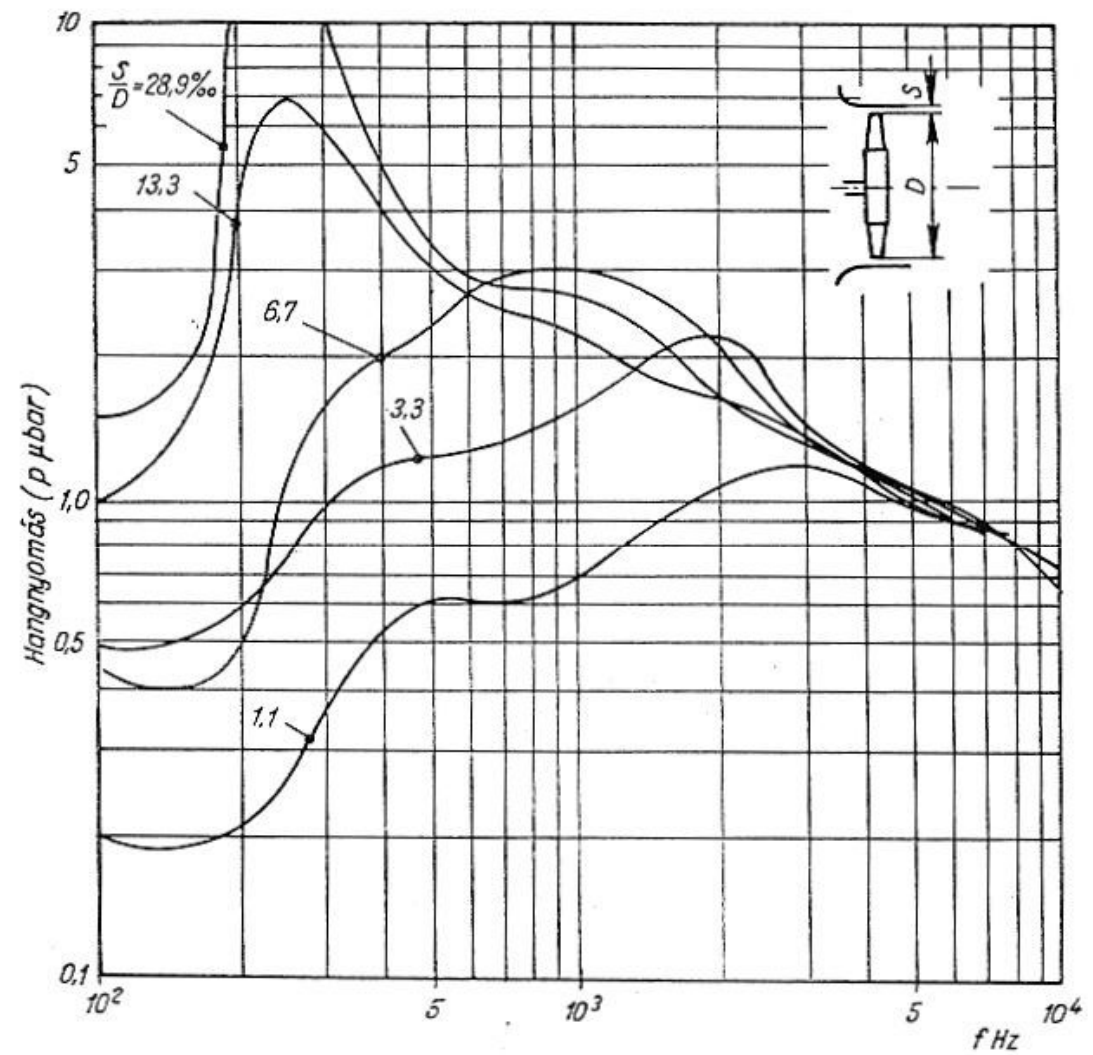

d) Turbulens zaj

e) Egymásrahatás-zaj

$$f = \frac{N_{tl} N_{jk} n}{k}$$

Radiális: $f = N_{jk} n$

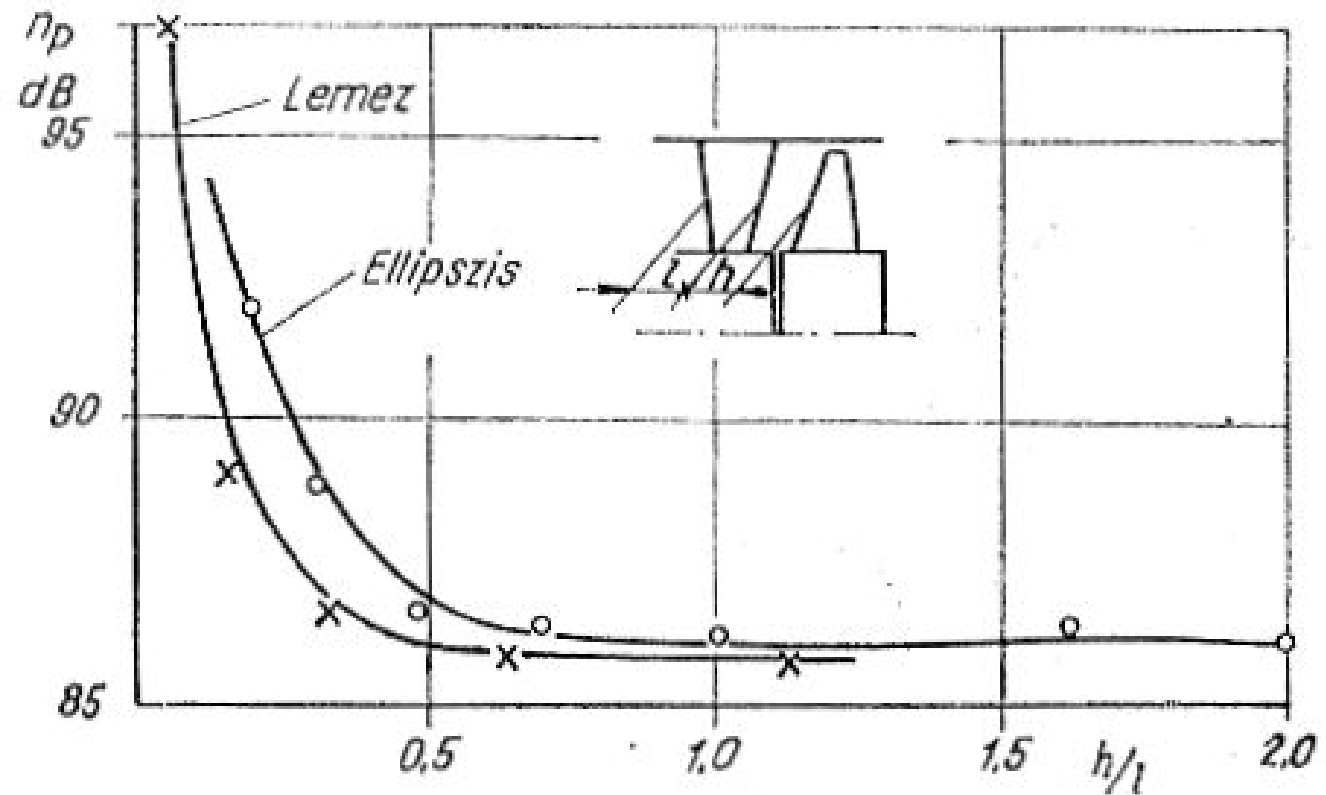

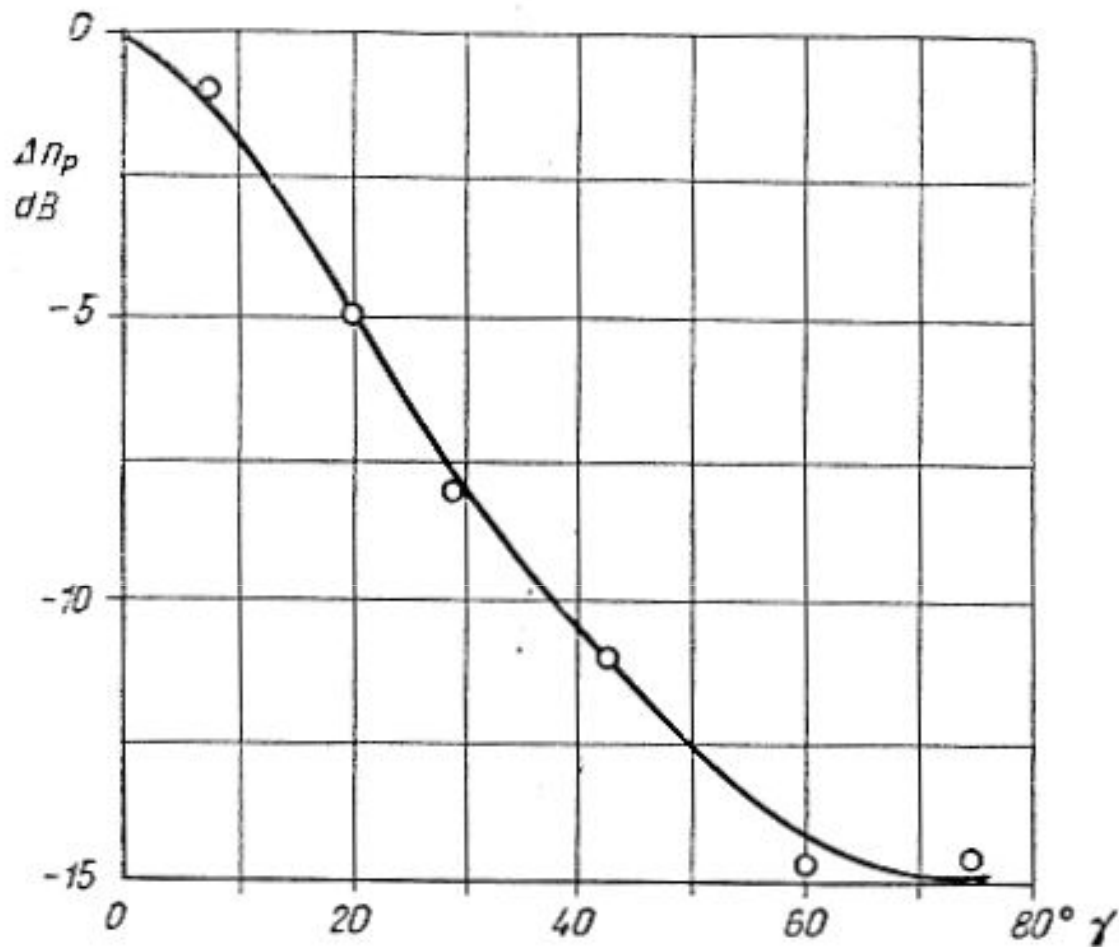

A terelőlapátok ferdítésének hatása az axiálventilátor zajára

9.4.2. A kibocsátott hangteljesítmény becslése

$$L_w \approx L_{w0} + 10 \lg \frac{q_V}{q_{V0}} + 20 \lg \frac{\Delta p_{\ddot{o}}}{\Delta p_{\ddot{o}0}}$$

$$L_{w0} = 40 \pm 4 \text{ dB} \quad q_{V0} = 1 \text{ m}^3 / \text{s} \quad \Delta p_{\ddot{o}0} = 1 \text{ Pa}$$

Megoszlás:

Közel azonos a szívó- és nyomóoldalon