

# FLOW MEASUREMENTS

Dr. János VAD, associate professor, Dept. Fluid Mechanics, BME

Vad, J. (2008), *Advanced flow measurements*. Műegyetemi Kiadó, 45085.

**Interactive presentations + industrial case studies**

**– PREMIUM SCORES**

**•Lab displays**

**2 Mid-term tests – Part A: closed book test (theory), Part B: open book test (solution of practical problems)**

**Laboratory measurements + presentation**

# 1. INTRODUCTION

## 1.1. Objectives of fluid flow measurements

### 1.1.1. *Global (integral) quantities*

General judgment of operation of fluid machinery and the connected fluid mechanical system, fault diagnostics (occasional studies)

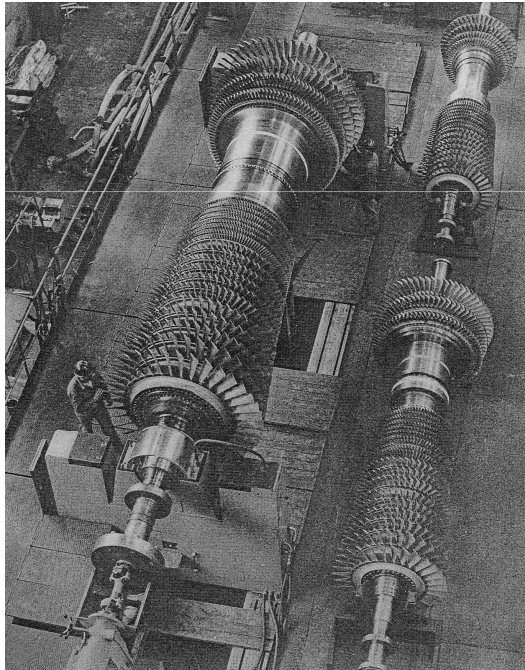

**Mass flow rate:** 
$$q_m = \int_{A_{duct}} \rho \underline{v} \cdot \underline{dA} \approx \rho \sum_{i=1}^n v_{\perp i} \Delta A_i$$

*Dr. János VAD: Flow measurements*

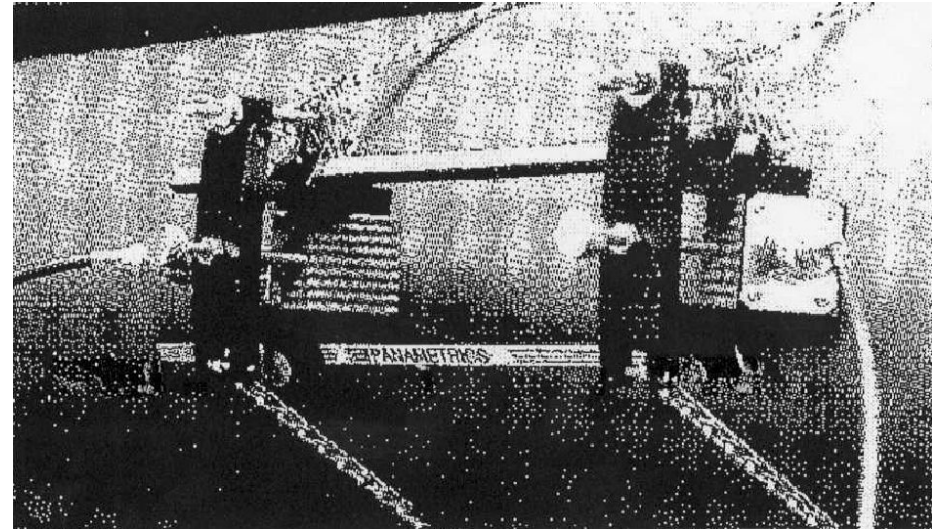
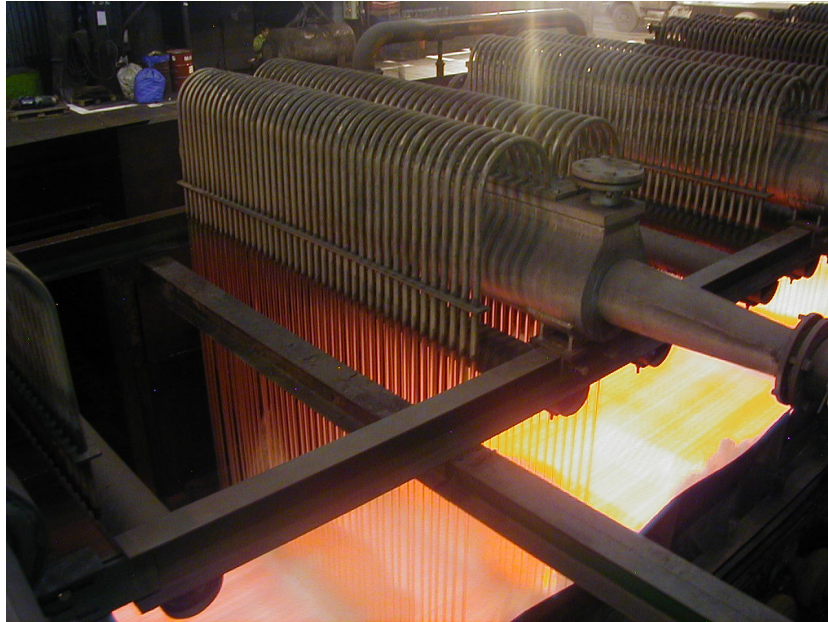

*Ultrasonic flowmeter*

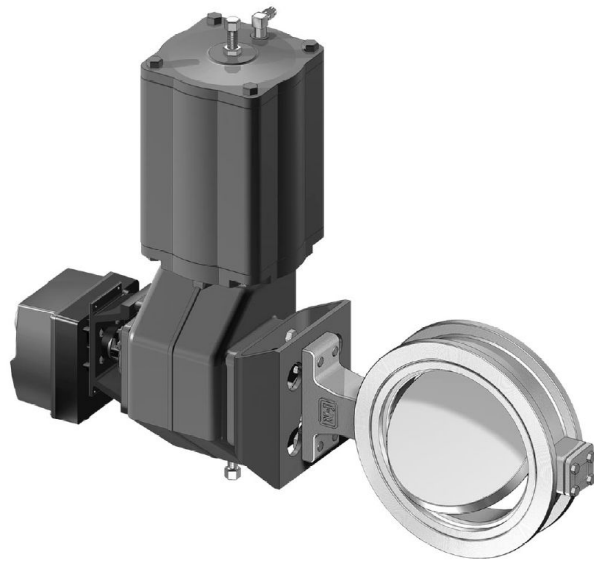

Providing measurement data for process control and automation

**Volume flow rate:**

$$q_V = \int_{A_{duct}} \underline{v} \, dA$$

*Dr. János VAD: Flow measurements*



## ***1.1.2. Local quantities, flow structure data***

Fault diagnostics, check of operational state

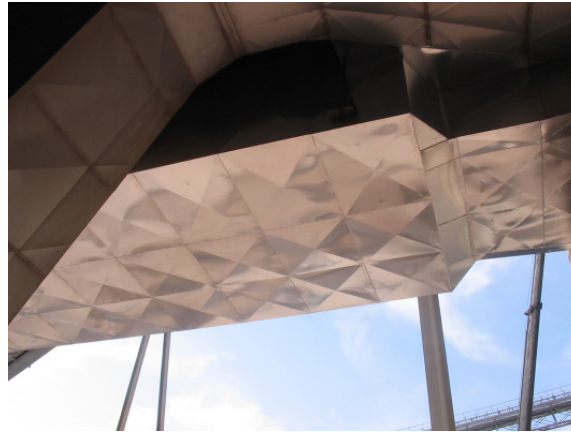

*Dr. János VAD: Flow measurements*

# Providing measurement data for industrial process control

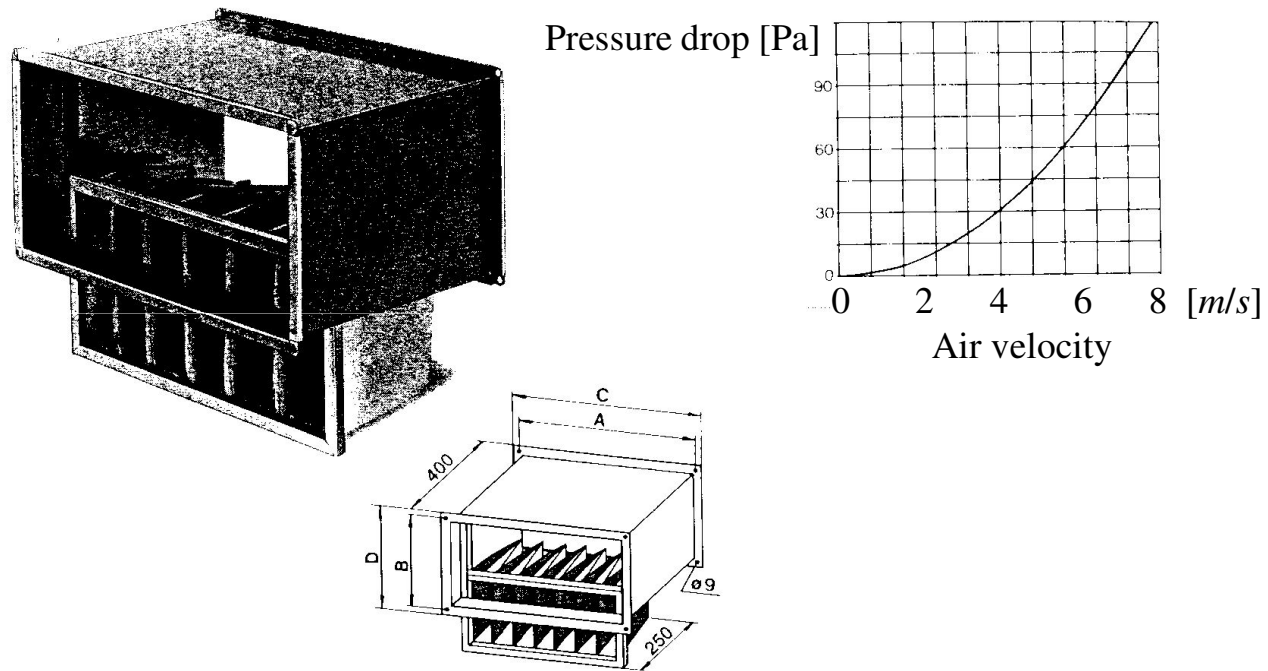

## Measurement-based research and development (R&D)

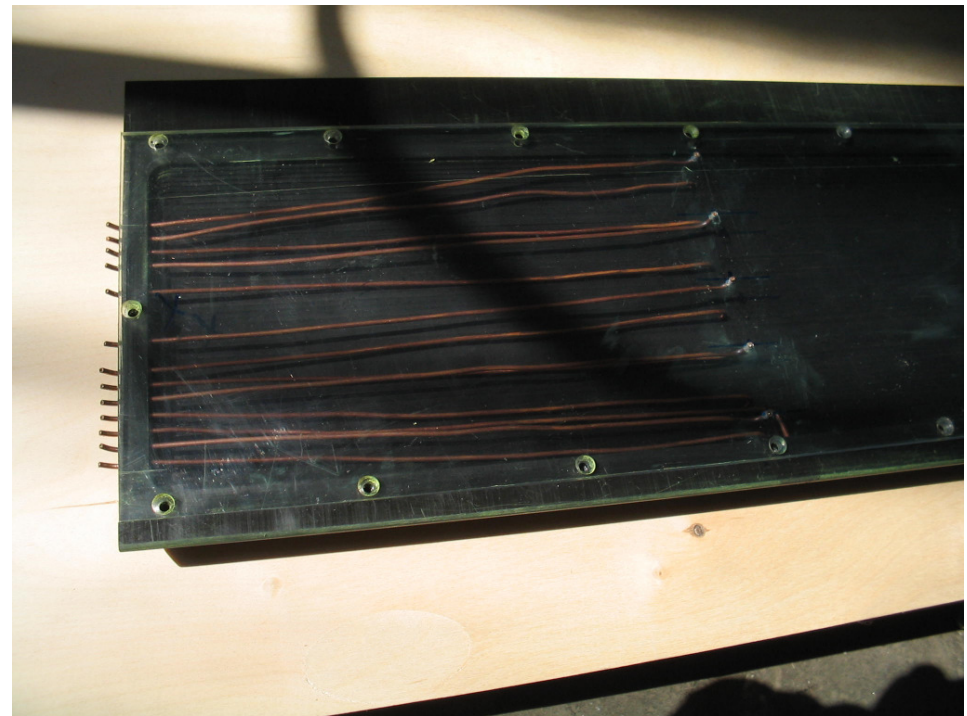
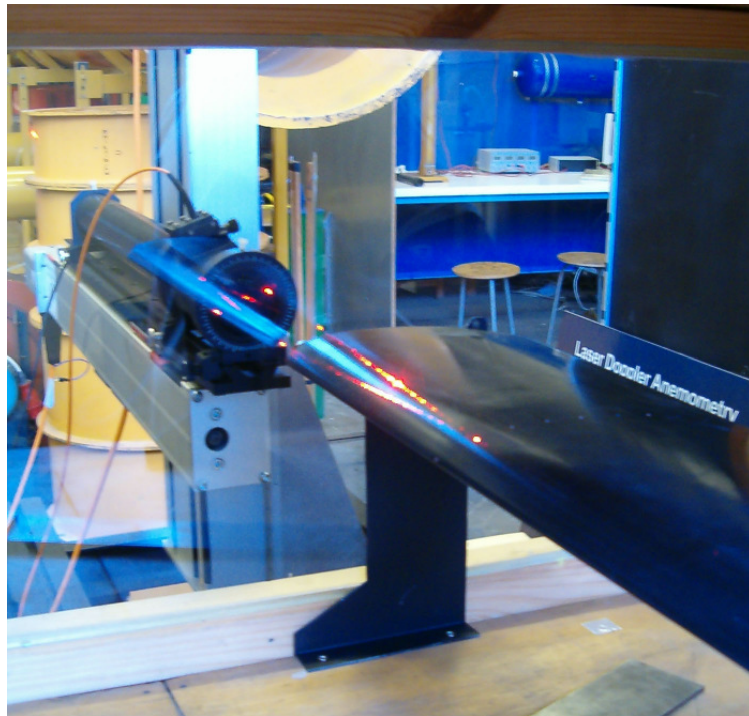

*Dr. János VAD: Flow measurements*

# Experimental validation of Computational Fluid Dynamics (CFD) tools

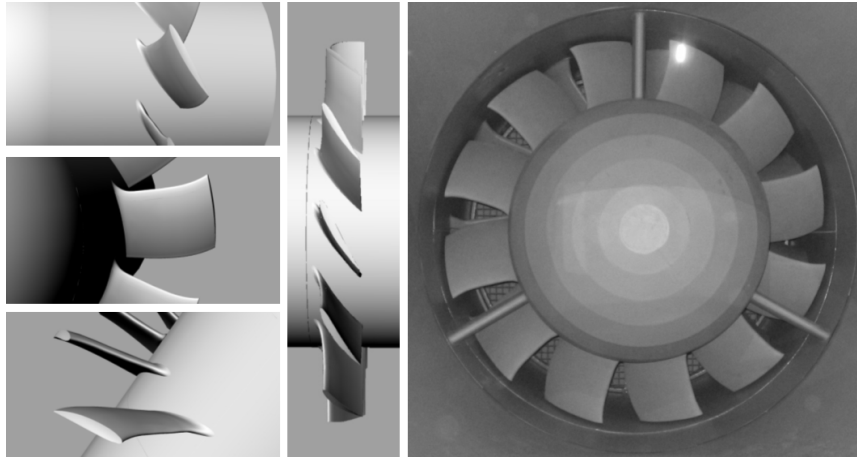

**LDA:**

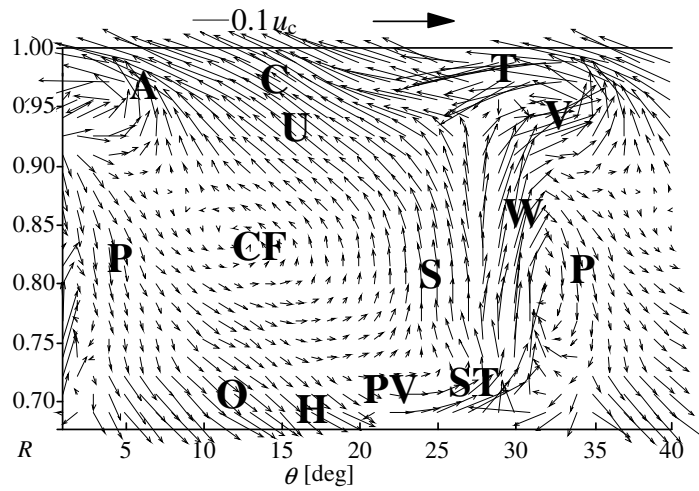

**CFD:**

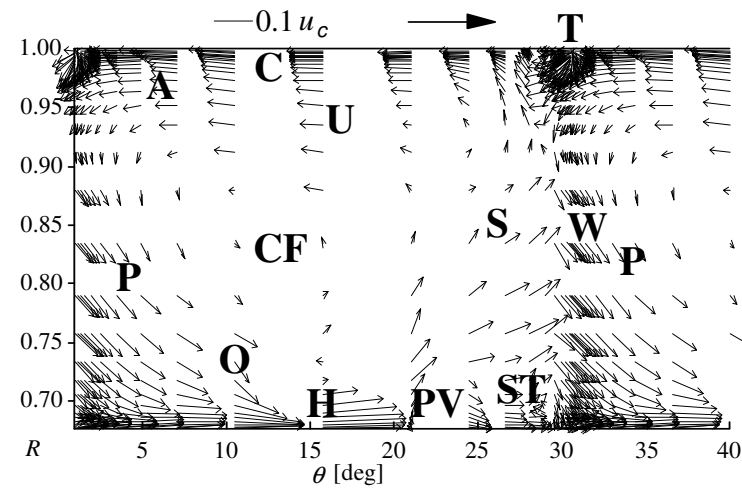

*Dr. János VAD: Flow measurements*

## 1.2. Measured quantities under discussion

Related to industrial applications and R&D:

### **Global quantities:**

- Volume flow rate
- Mass flow rate

### **Local quantities:**

#### ***Scalar quantities:***

- Pressure (temporal mean and fluctuating)
- Temperature
- Concentration of another phase

#### ***Vectorial quantities:***

- Velocity (temporal mean and fluctuating)



### 1.3. “Advanced flow measurements”: aspects of being “advanced”

Demand	Examples for instrumentation
“Small” measurement uncertainty	Laser Doppler Anemometry (LDA): velocity measurement with 0.1 % relative uncertainty
“Wide” measurement range	LDA equipped with high-speed data acquisition card, capable for measurement of sign of velocity: velocity from 0 m/s up to supersonic flow
“High” spatial resolution	LDA: the size of the measurement volume is in the order of magnitude of 0.1 mm ( $\Leftrightarrow$ Pitot-static probe)
“High” temporal resolution for investigation of time-dependent processes (e.g. turbulence)	Hot wire anemometry (Constant temperature anemometry: CTA) ( $\Leftrightarrow$ Pitot-static probe)

“High” directional resolution for measurement of vector quantities	LDA: the interference fringe system defines the direction of velocity component being measured ( $\Leftrightarrow$ Pitot-static probe)
“Low” directional resolution for measurement of scalar quantities	Pitot-static (Prandtl) probe for dynamic pressure measurements: directionally insensitive in the range of $\pm 15^\circ$ (this is a disadvantage if the velocity is to be determined for deduction of volume flow rate)
Multi-dimensionality	1D, 2D, 3D LDA and CTA, stereo PIV
Limited need for calibration (stable internal parameters)	LDA: NO need for calibration, “black box”: NOT ALLOWED to adjust ( $\Leftrightarrow$ CTA)
Easy-to-use, “plug and play”	Propeller anemometer ( $\Leftrightarrow$ LDA)

Reliable operation in a wide application area: under heavy circumstances (dusty, hot, humid, aggressive industrial environment)	S-probe ( $\Leftrightarrow$ LDA)
Application areas not servable with other methods; remote measurements	Laser vibrometer ( $\Leftrightarrow$ piezo-electric accelerometer)
“Limited” disturbance of the flow to be measured: “non-contact” / “non-intrusive” / “non-invasive” techniques	Ultrasound flowmeter ( $\Leftrightarrow$ Solid-state probes)
Limited necessity to manipulate the equipment to be measured	Laser vibrometer, ultrasound flowmeter ( $\Leftrightarrow$ throughflow orifice meter)

Electronic output signal for advanced representation of data and for process control	Electronic pressure transducer ( $\Leftrightarrow$ U-type liquid manometer)
Computer-supported, automated measurement (calibration, traversing, data acquisition, data processing, data storage, data representation...)	Particle Image Velocimetry (PIV) ( $\Leftrightarrow$ Pitot-static probe)
“Low” expenses	Pitot-static probe ( $\Leftrightarrow$ LDA)



## 1.4. Special notes on advanced flow measurements

### A/ Measurement methods: selection according to the demands

Velocity measurement:

<b>Technique</b>	Pitot-static probe	1-component CTA or LDA	2-component LDA
<b>Aim</b>	Magnitude of temporal mean velocity, point- like	1 temporal mean (and fluctuating) velocity component, point- like	2 velocity components, point-like
<b>O. m. in expenses</b>	0.5 kEUR	25 kEUR	100 kEUR

<b>Technique</b>	3-component LDA	2-component PIV	Stereo PIV
<b>Aim</b>	3 velocity components, point-like	2 velocity components, in a plane	3 velocity components, in a plane
<b>O. m. in expenses</b>	<b>200 kEUR</b>	<b>200 kEUR</b>	<b>400 kEUR</b>

***...3 velocity components in space... Laser holography...***

**B/ “Advanced” only IF: the entire experimental procedure and evaluation is also advanced**

- Supersonic wind tunnel: long, expensive preparation → short meas.

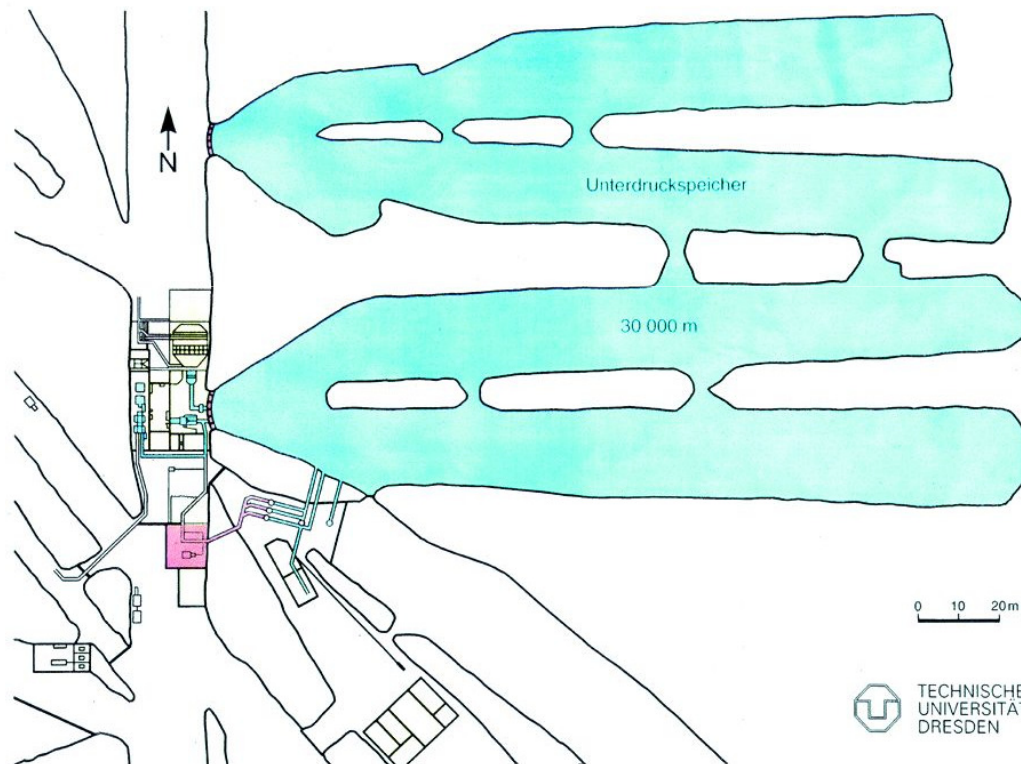

- IC test engine made of glass: expensive preparation → short meas.

C/ Paradox: „we need to know the answer before we begin.”  
“Without theory the facts remain silent.”

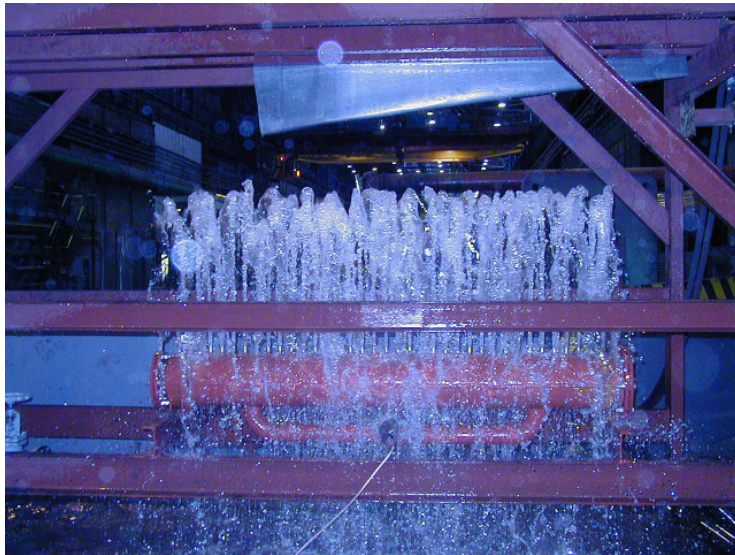

*Cooling water distributor*

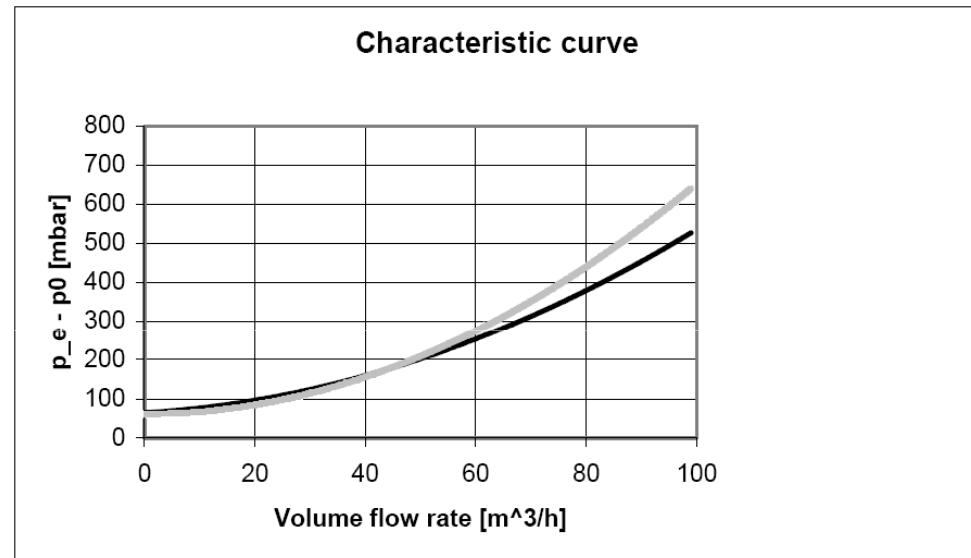



## Laser Doppler Anemometry – how to check?

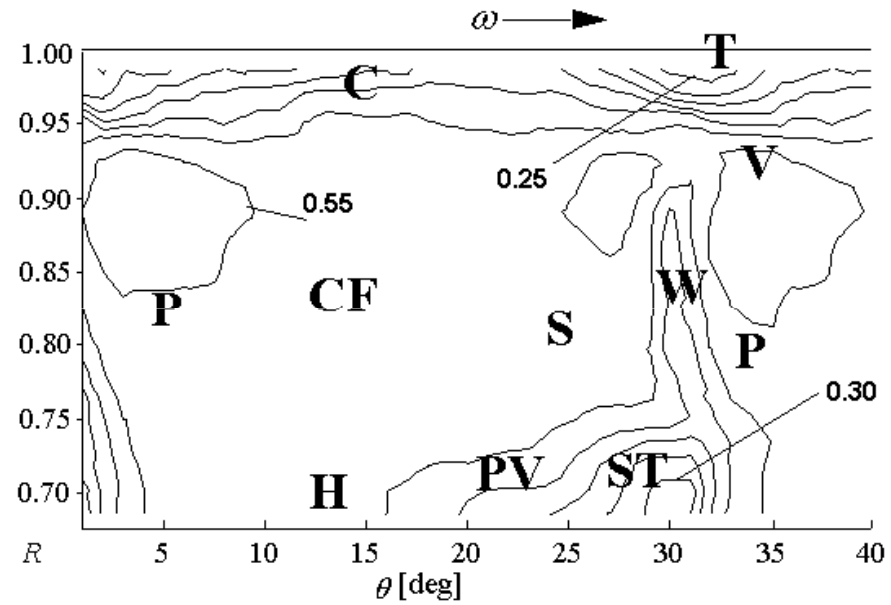
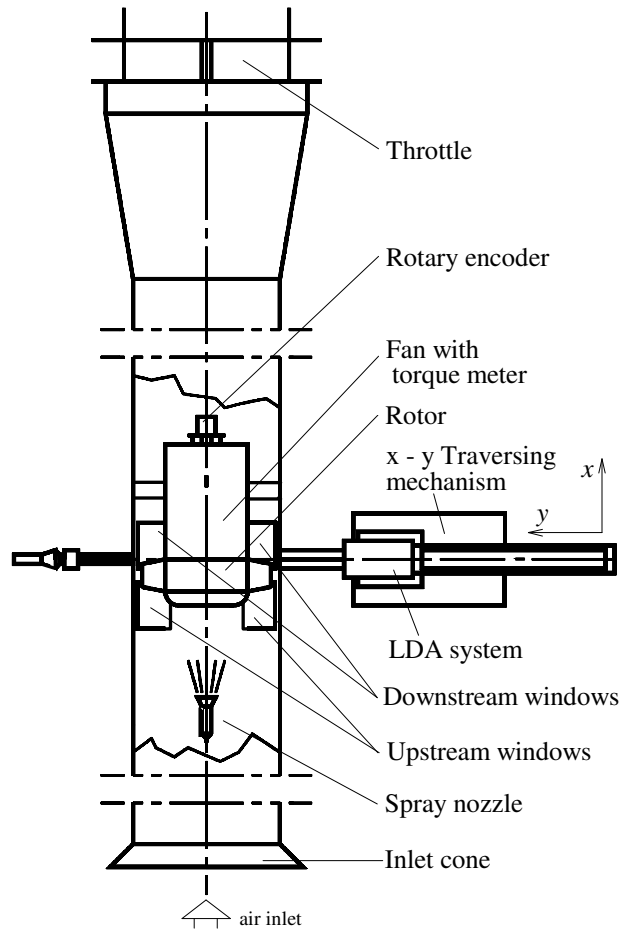

*Axial velocity distribution downstream of one blade passage*

## D/ Full exploitation of the measurement technique

