

8. SPECIALISED FLOWMETERS

8.1. Ultrasonic flowmeters

8.1.1. Application example: gas well

8.1.2. Principles

$$f_1 - f_2 = 2 \bar{v} f_1 \frac{\cos \theta}{a}$$

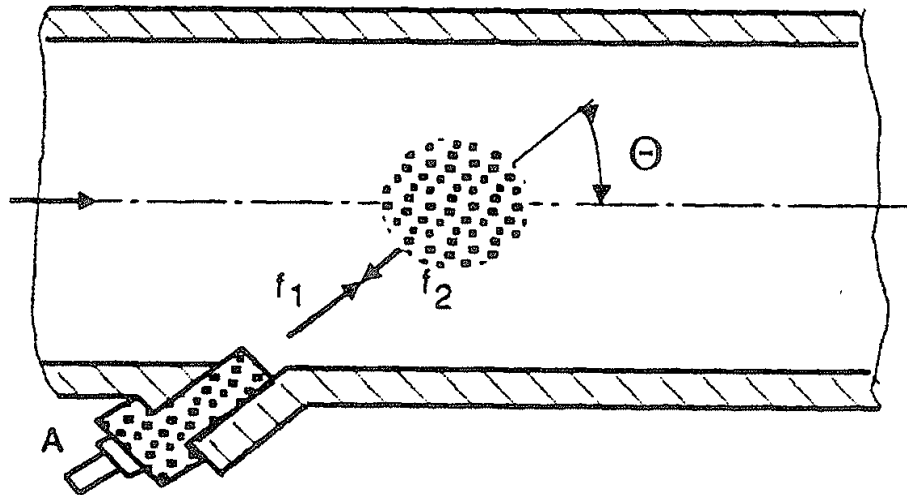

$$\frac{f_1 - f_2}{f_1} \ll 1$$

Doppler principle

$$a_A = a + v \cos \theta$$

$$a_B = a - v \cos \theta$$

$$\bar{v} = \frac{1}{L} \int_L v \, dL$$

$$\bar{a}_A = a + \bar{v} \cos \theta = \frac{L}{t_A}$$

$$\bar{a}_B = a - \bar{v} \cos \theta = \frac{L}{t_B}$$

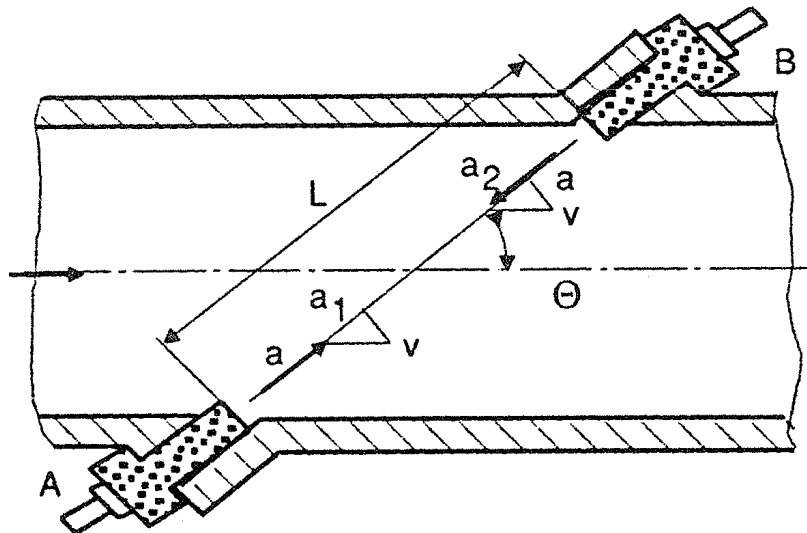

Transit time difference principle

$$\begin{aligned} \bar{v} &= \frac{L}{2 \cos \theta} \left(\frac{1}{t_A} - \frac{1}{t_B} \right) = \frac{L}{2 \cos \theta} \left(\frac{t_B - t_A}{t_A t_B} \right) = (t_B - t_A) \frac{1}{2 \cos \theta} \frac{1}{L} \frac{L}{t_A} \frac{L}{t_B} = \\ &= (t_B - t_A) \frac{1}{L 2 \cos \theta} \bar{a}_A \bar{a}_B \approx (t_B - t_A) \frac{a^2}{L 2 \cos \theta} \end{aligned}$$

$$q_V = \bar{v} A$$

$$\bar{v} = \frac{L}{2 \cos \theta} \left(\frac{1}{t_A} - \frac{1}{t_{A^*}} \right) = \frac{L}{2 \cos \theta} (f_A - f_{A^*})$$

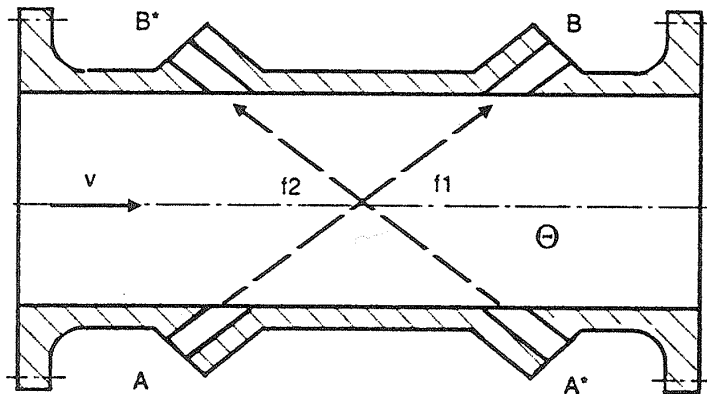

Frequency tracking (“Sing around”) principle



US300PM (main unit)



Left: Transducer for large pipes

Middle: Transducer for small- and medium-sized pipes

Right: Wall thickness probe (for general temperature)

Steel industry application (contaminated cooling water)

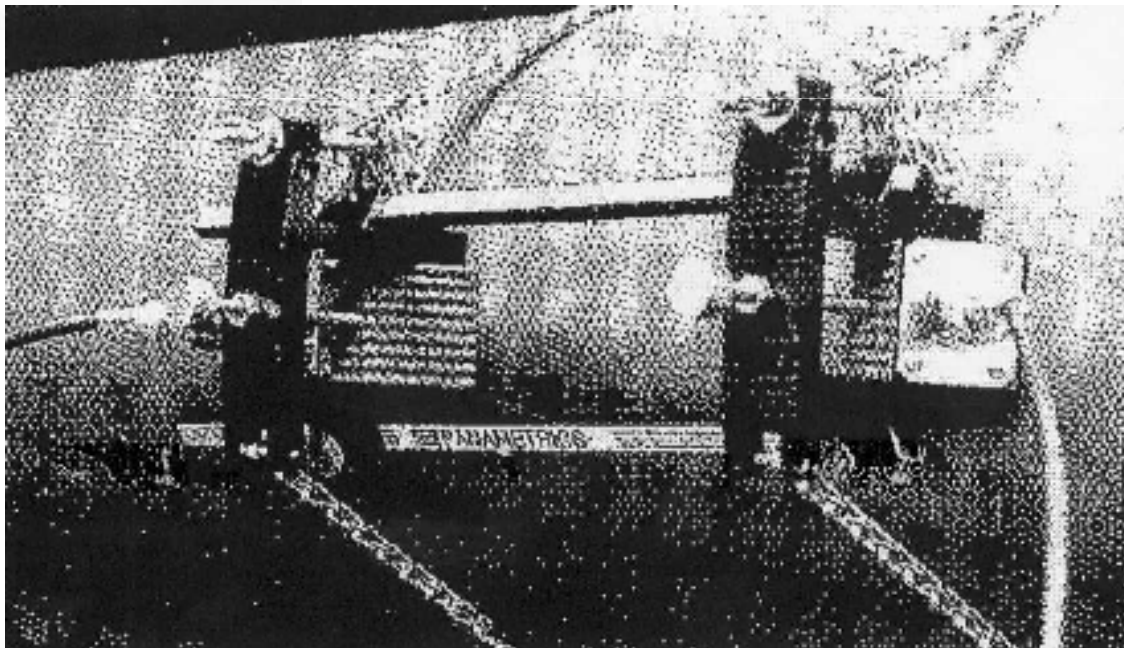
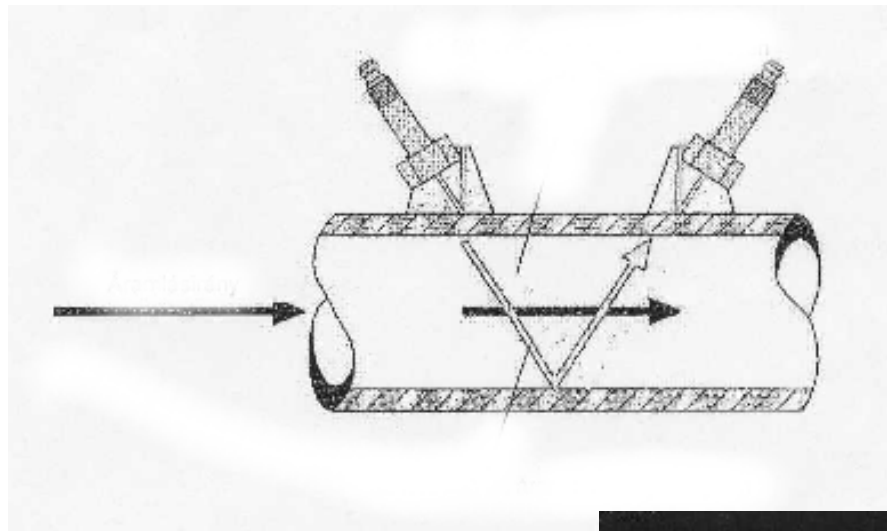

Dr. János VAD: Flow measurements

ADVANTAGES:

- Non-intrusiveness
- No pressure drop
- Long life cycle
- Subsequently mountable
- The measurement principle is independent from the fluid density

•LIMITATIONS / DISADVANTAGES:

- The relative measurement error is in the order of magnitude of 1 – 2 % or even higher
- Contacting with fluid of high temperature (say above 200 °C), the piezo-electric elements usually do not operate properly
- Acoustic transparency of the fluid is necessary
- Temperature dependence of the measurement results \Leftrightarrow “Sing around” concept
- In multiphase flows, the acoustic signal may be absorbed \Rightarrow increased noise
- The contamination of the fluid determines the technique to be applied. Highly contaminated fluids cannot be measured.
- Sensitivity to the adjustment of geometry, i.e. L and θ
- The mean velocity is determined not in the entire cross-section but along a linear path \Rightarrow increased measurement uncertainty, sensitivity to the velocity profile, i.e. no reliable measurement can be carried out in strongly disturbed flow e.g. close downstream of elbows or valves
- Deposit on the sensors \Rightarrow increased signal-to-noise ratio
- The errors are increased if the cross-section is not filled fully with the liquid (no measurement for free surface fluids)

CASE STUDY – Natural gas well

AMESim model:

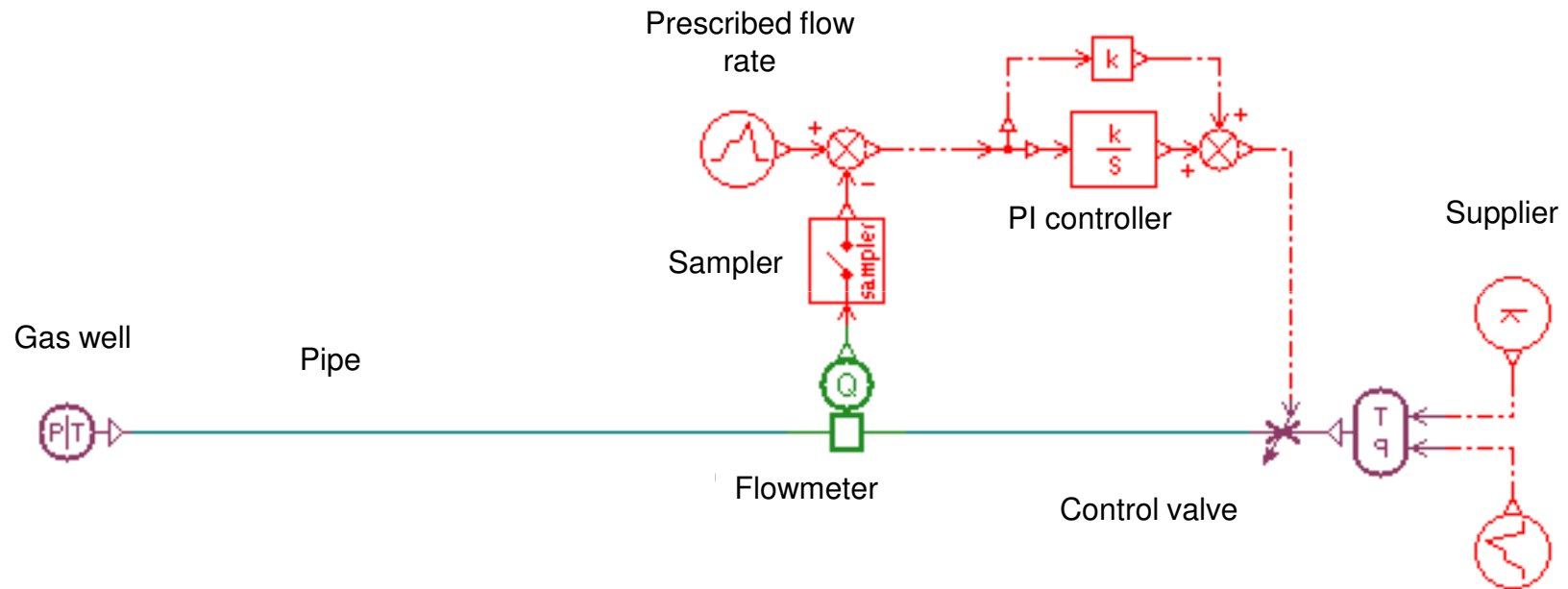

„Hydrate corks” (solidified minerals) passing through the measurement section in the pipeline: measurement technical problems

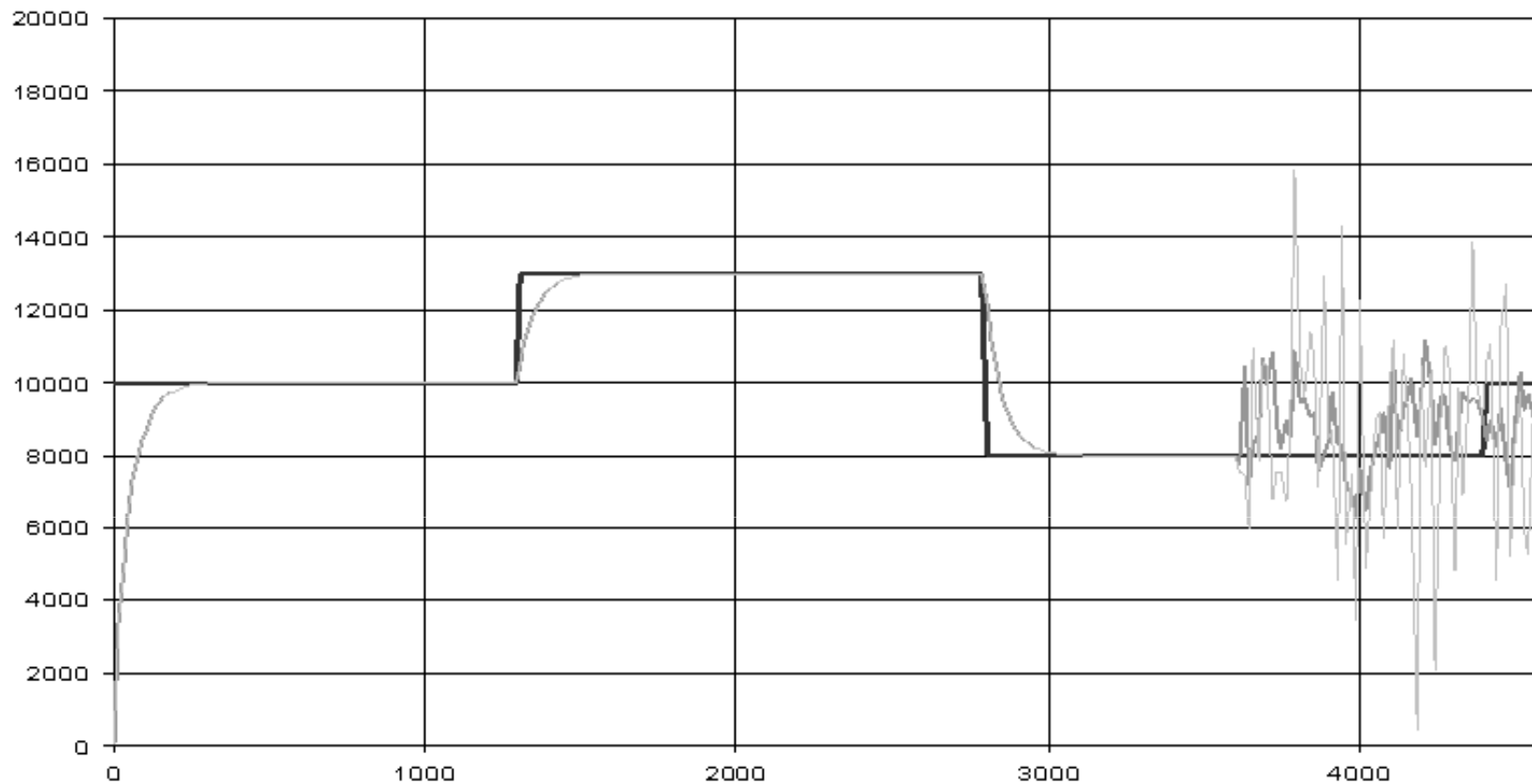

Faster PI control: inability to follow the ordering signal when the measurement is disturbed



Setting the PI control to slower mode: increased reaction time but less sensitivity to measurement anomalies

8.2. Magneto-inductive flowmeters (magneto-hydrodynamic, MHD)

8.2.1. Application examples: slurry, paper pulp

$$u = B L v \qquad q_v = \frac{u D \pi}{4 B}$$

Faraday effect

8.2.2. Principle and layout

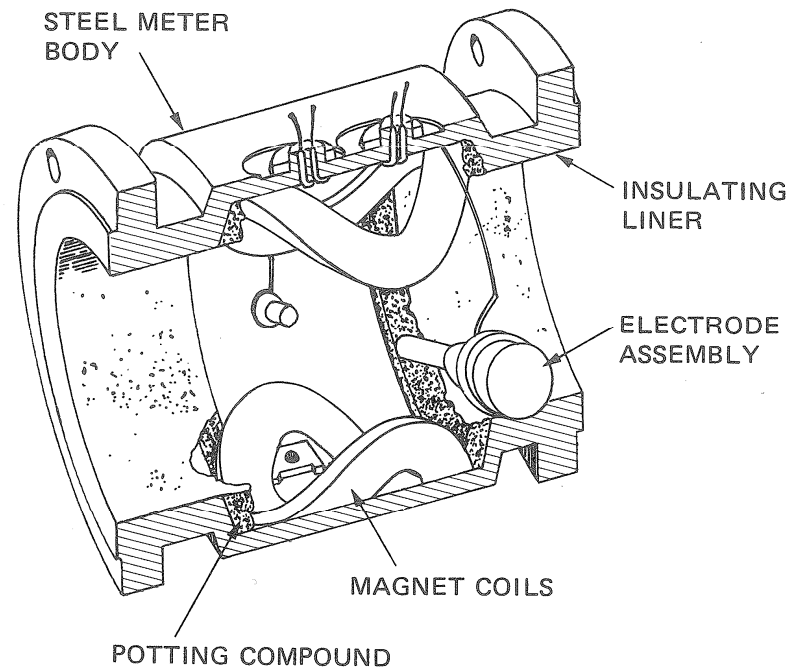
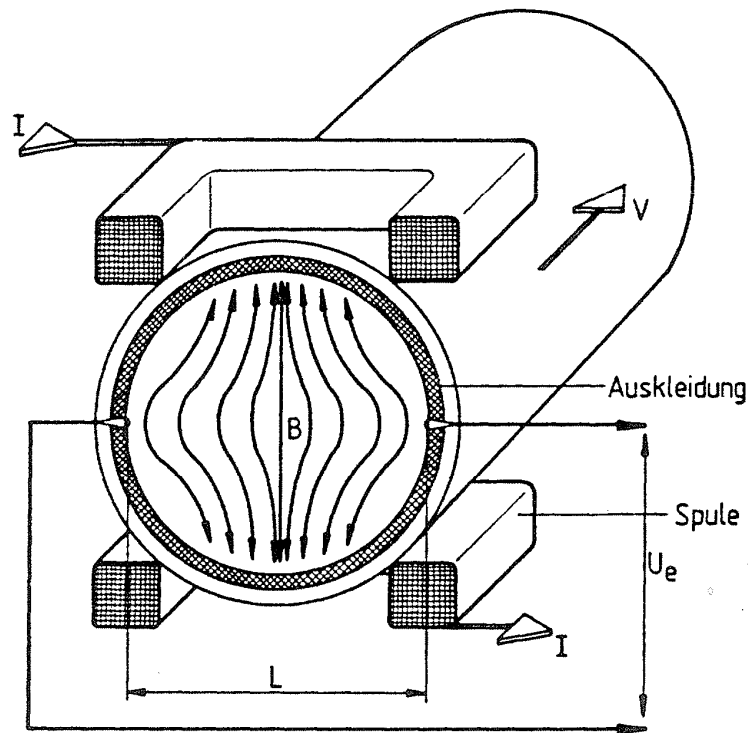

- 2 main units: transducer, data processor
- Withstand to mechanical and chemical load
- Flanged and sandwich layouts
- Water-proof layout possible



www.gammaanalcont.hu

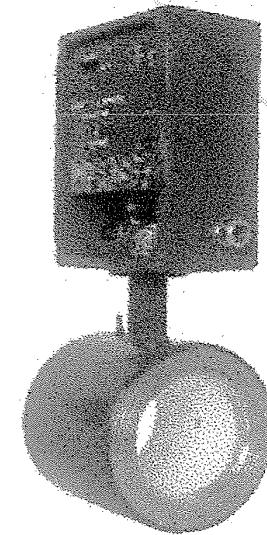
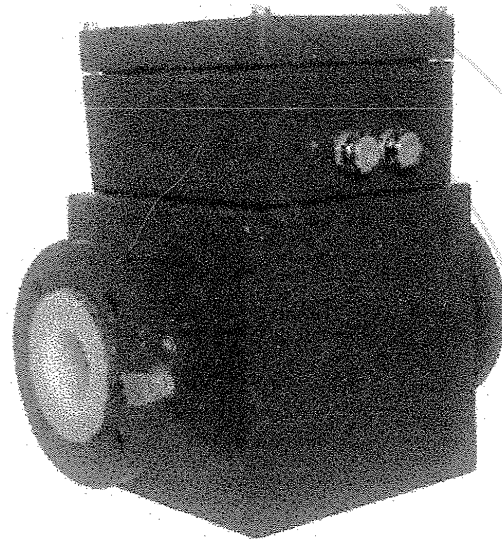
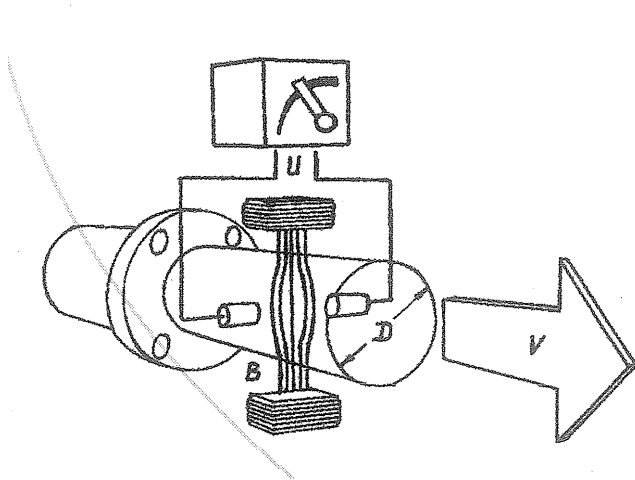

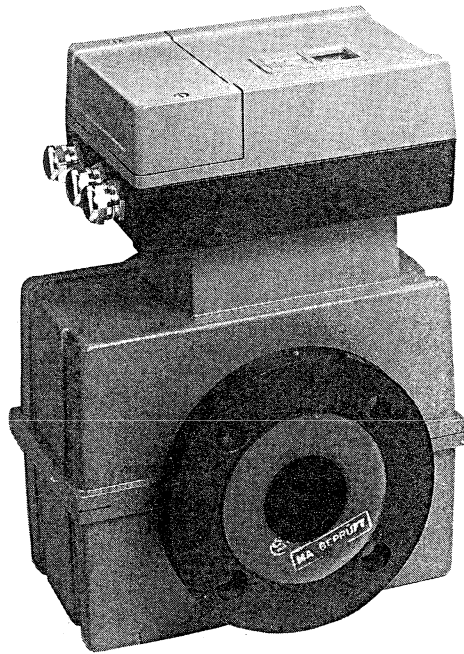

Integral Flowmeter



Remote Flowtube

ADVANTAGES:

- Above a conductivity limit: the principle is independent from conductivity
- Unsteady flow measurements
- Measurements are independent from fluid pressure, density, temperature, kinematic viscosity
- Minimum dependence on the velocity profile \Rightarrow strongly disturbed flows can also be measured
- Limited space demand, arbitrary location of measurements. 3 to 5 pipe diameter undisturbed upstream and downstream sections are to be guaranteed in order to limit the measurement error, but this requirement is still loose compared e.g. to a throughflow orifice meter.
- Liquid with solid impurities can be measured
- No pressure drop, non-intrusiveness
- High, certified, guaranteed accuracy (relative error 0.2 to 1 %)
- High linearity, also for dynamic effects
- Stable internal parameters, no calibration required
- Low maintenance costs (cleaning etc.)

• **LIMITATIONS / DISADVANTAGES:**

- Electric conductivity of the fluid is necessary \Rightarrow only liquids, but even among liquids, no measurement is possible for petrochemical products (oil, gasoline, petrol, etc.)
- Deposit (contamination) on the pipe wall \Rightarrow reduced voltage signal \Rightarrow reduced signal-to-noise ratio
- If air or other gases are present in the liquid in X % volume fraction \Rightarrow the measurement error increases by approx. X %.
- If the flow cross-section is not filled at X area percentage \Rightarrow the problem is as above, the measurement error increases by approx. X %.
- The life cycle of the electrodes is limited according to the fluid temperature and pressure.
- Increased zero-point error

8.3. Capacitive cross-correlation technique

8.3.1. Application examples: plastic granulates

8.3.2. Principle and layout

$$v = \frac{d}{\tau_m}$$

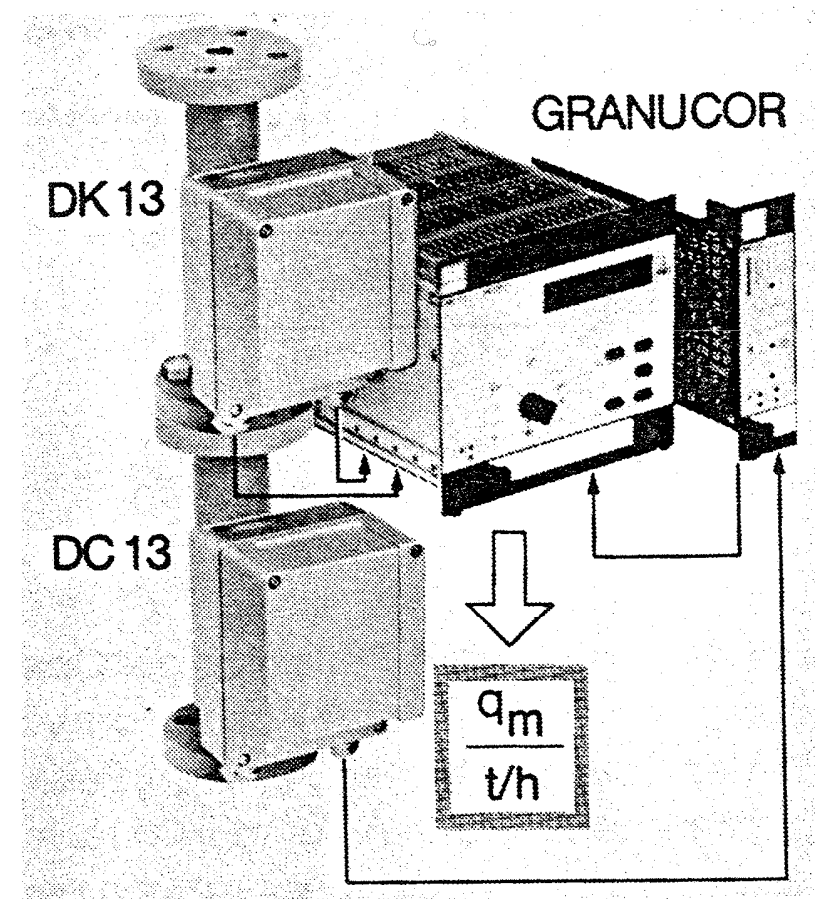
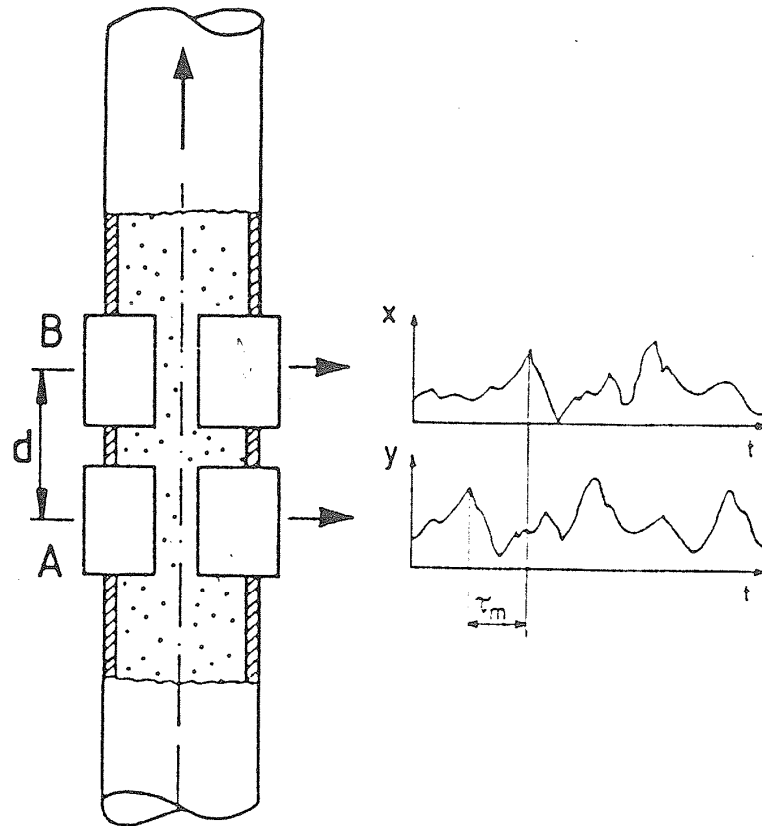

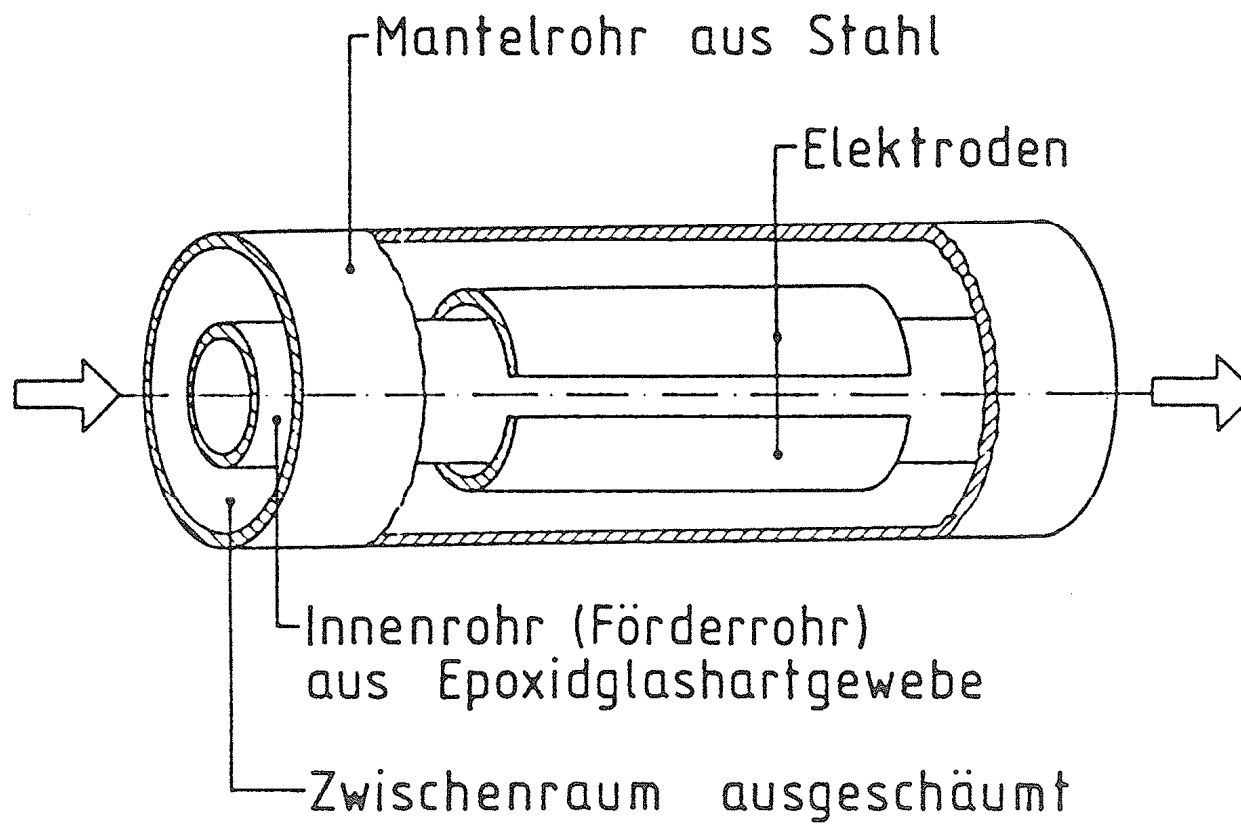

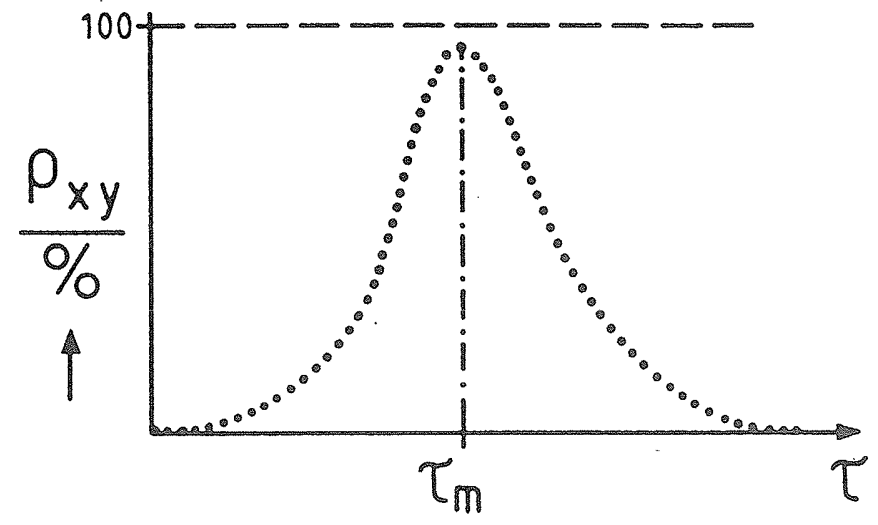
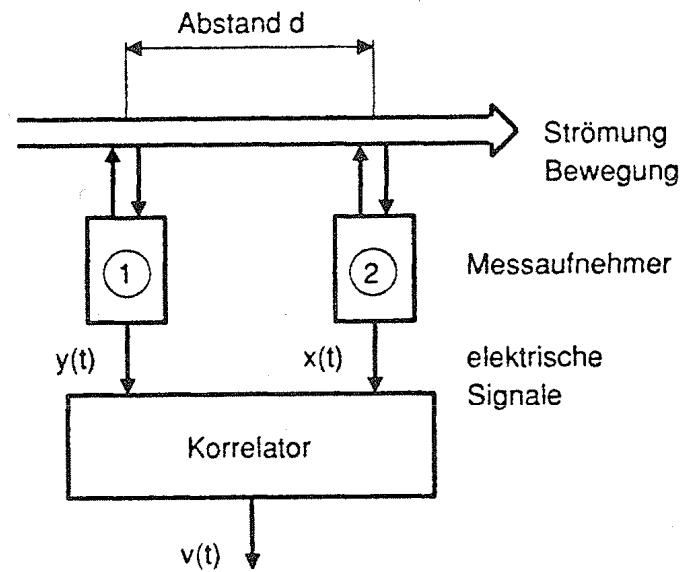

ADVANTAGES:

- Statistic method, enabling the limitation of measurement errors
- Two-phase flows can be measured
- No temperature dependence
- Non-intrusive measurement

LIMITATIONS / DISADVANTAGES:

- Increased space demand. The minimum displacement between two electrodes is governed by the sensor size, particle size, maximum sampling frequency, and the required accuracy.
- The work experiences are still limited
- High investment costs
- No measurements are possible close to the zero point of flow rate

8.4. Vortex shedding flowmeters

8.4.1. Application examples: clean gases, steam

8.4.2. Principle

$$Str = \frac{f \cdot d}{v}$$

$$v = \frac{d}{Str} \cdot f$$

$$Re = \frac{v \cdot d}{\nu}$$

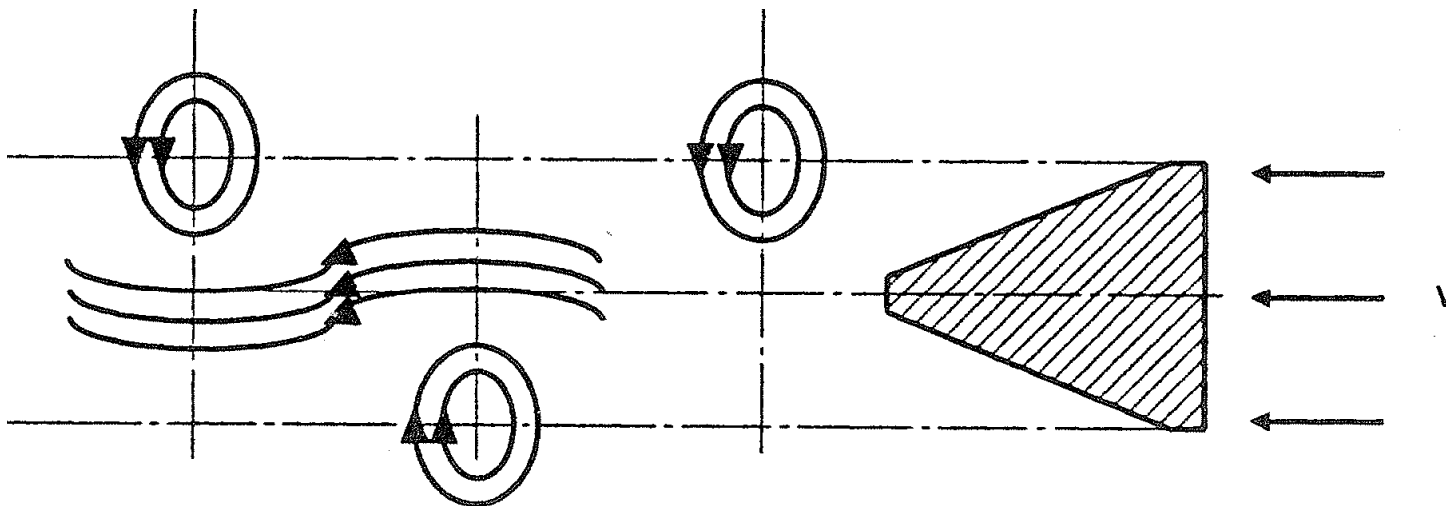

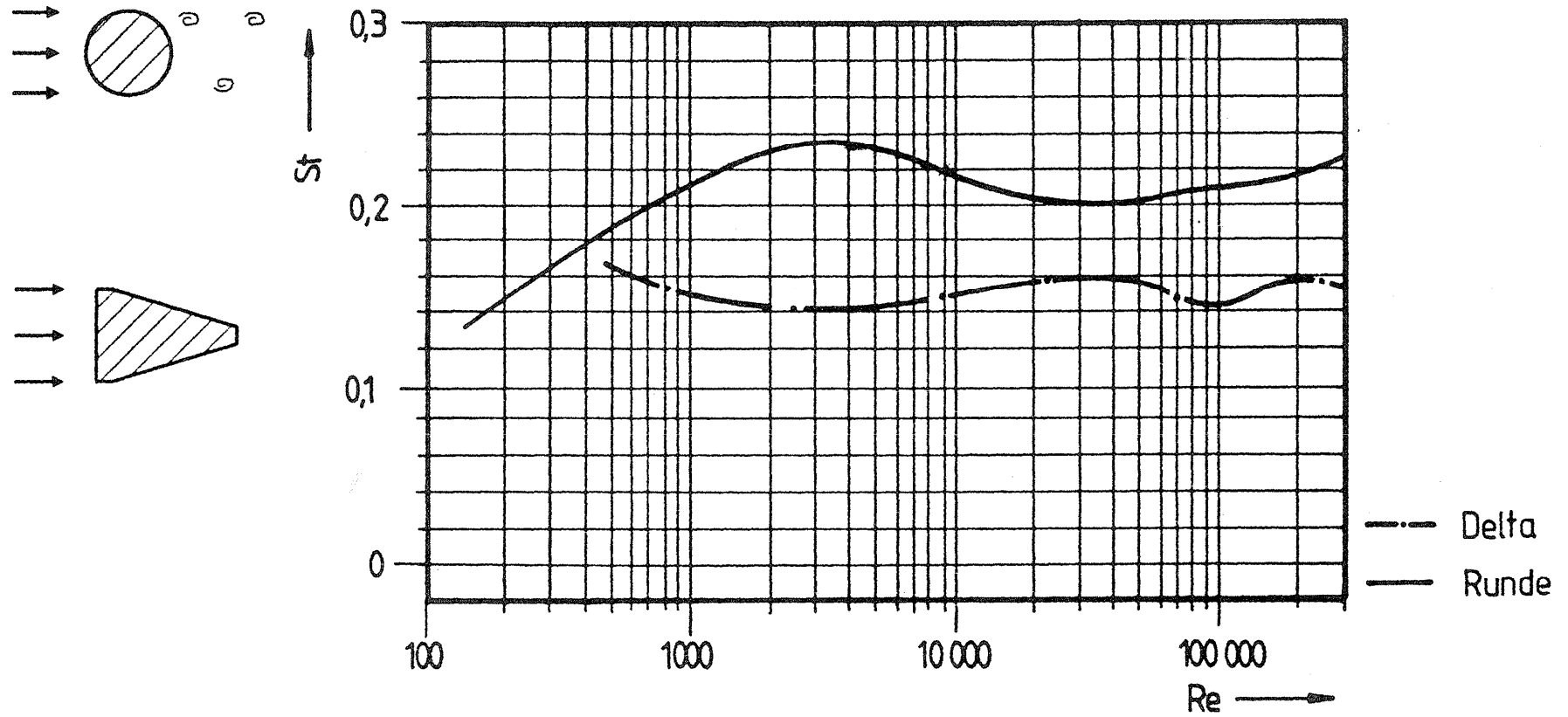

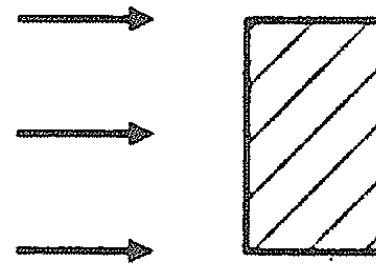
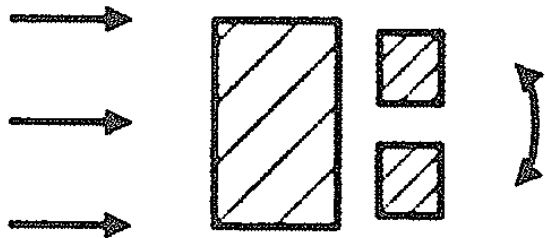
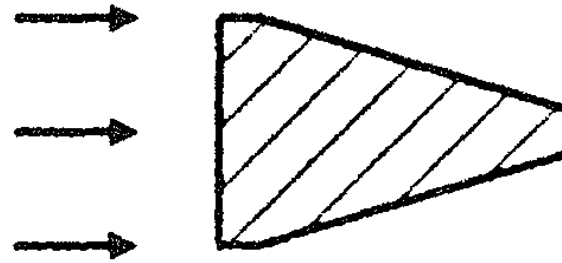
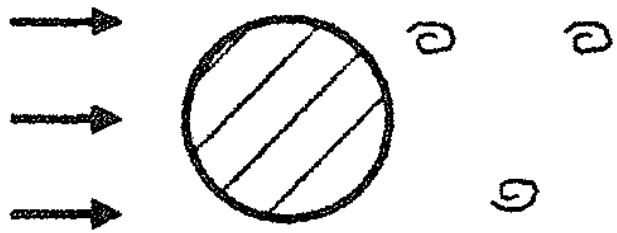

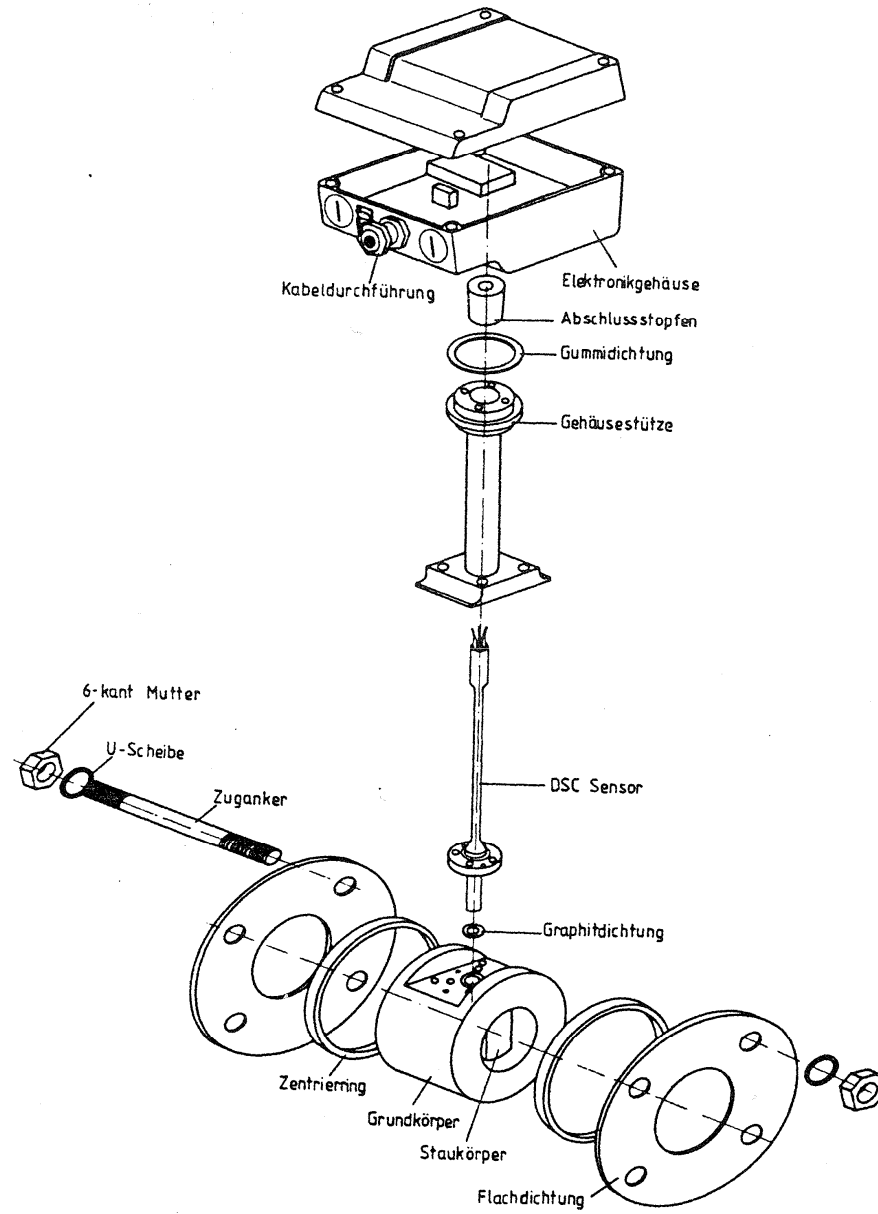



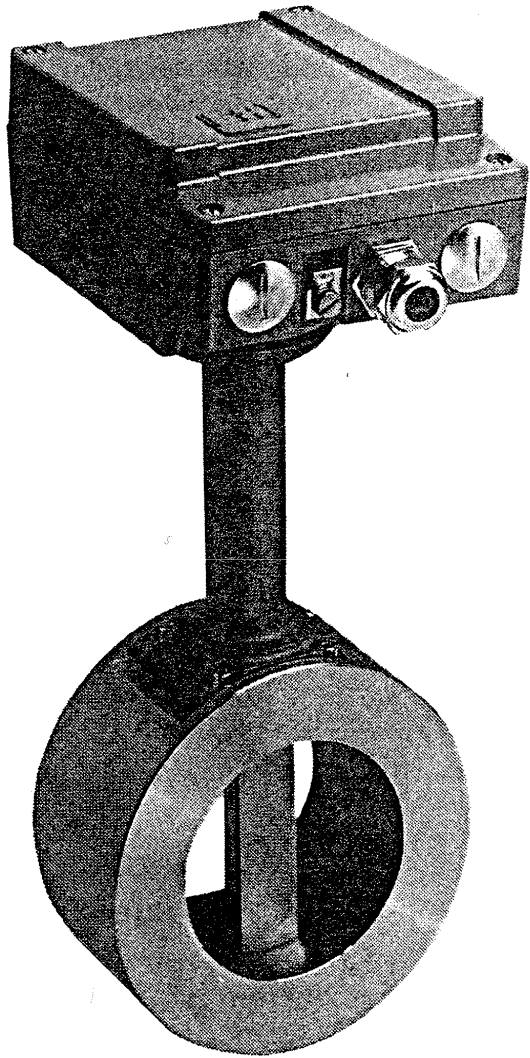

Dr. János VAD: Flow measurements

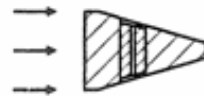

Dr. János VAD: Flow measurements

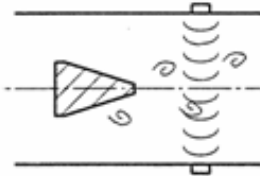
Principle	Figure	Comments	Applications	Limits
Thermistors		The thermistors are heated with constant current. The alteration in temperature due to vortex shedding, and as a result, in the thermistor resistance, is detected by means of a Wheatstone bridge comprising the thermistors.	<ul style="list-style-type: none"> - Clean gases - Clean liquids 	<ul style="list-style-type: none"> - Sensitivity to contamination - No resistance to temperature shocks
Pressure sensors		Flexible membranes comprised in capacitance elements \Rightarrow pressure fluctuation \Rightarrow membrane deformation \Rightarrow modulated capacitance	<ul style="list-style-type: none"> - Liquids - Gases - Low pressure steam 	<ul style="list-style-type: none"> - Below 150 °C - Time-dependent characteristics of membranes - High pressure fluctuation necessary
Mechanical sensors		The pressure fluctuation results in the periodic displacement of the sphere or disk in the o. m. of 0.1 mm \Rightarrow actuating a microswitch	<ul style="list-style-type: none"> - Warm water - Steam - Low temperature liquids 	<ul style="list-style-type: none"> - Sensitive to contamination - The condensed water may block the microswitch - Temperature shock may result in blockage or rupture due to thermal dilatation
Strain gauges		Elastic mounting of the strut \Rightarrow deformation due to cross-stream oscillation \Rightarrow 10 μm o.m deformation measured	<ul style="list-style-type: none"> - Gases - Liquids 	Up to cca. 100...°C
Ultrasound sensors		Ultrasound modulated by the vortex street	<ul style="list-style-type: none"> - Gases - Liquids 	<ul style="list-style-type: none"> - Sensitive to external acoustic and vibration effects

ADVANTAGES:

- No effect of density and kinematic viscosity in liquids
- Broad-scale approximate linearity, independently from fluid density, kinematic viscosity, and pressure
- Moderate installation costs
- High dynamic response
- Limited error (below 1 %)
- Temporal stability of parameters
- Low pressure drop
- The vortex shedding principle is independent from the temperature. The temperature is limited „only” by the sensors. The range of -200 to 400 °C can be usually measured. E.g. high temperature gas and steam measured.

LIMITATIONS / DISADVANTAGES:

- Reynolds number limit to ensure moderate errors: cca. 20 000 to $2 \cdot 10^6$
- No measurements are possible if no vortices are shed
- Single phase flow is recommended. Multiphase: problems with contamination, vortex formation and abrasion of the strut.
- No measurement is possible if the measurement cross-section is not fully filled with the fluid
- Increased errors if no undisturbed upstream and downstream pipe sections are guaranteed
- Dependence on the velocity profile \Rightarrow application of upstream straighteners (e.g. honeycombs) is recommended for uniformisation of the velocity profile
- Risk of cavitation erosion of the strut \Rightarrow increased upstream pressure may be needed
- Not applicable for high viscosity fluids (lack of vortex shedding)
- Not applicable for pulsing flow