

Budapesti University of Technology and Economics

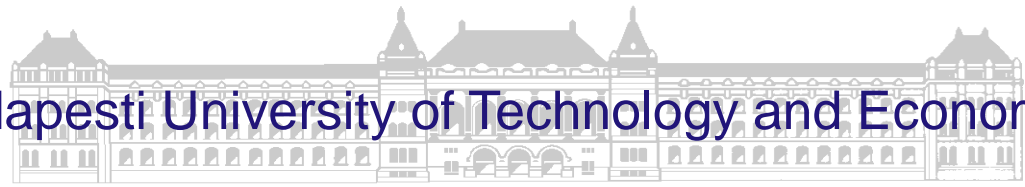

Department of Fluid Mechanics

www.ara.bme.hu

Pre-measurement class I.

Department administrator of measurements:
Dr. Csaba Horváth horvath@ara.bme.hu

2019.
spring

Department of Fluid Mechanics H-1111 Bertalan Lajos u. 4-6. „AE” building

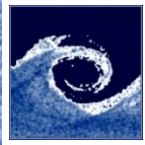

General information

- Department webpage: www.ara.bme.hu
- Student information page: www.ara.bme.hu/poseidon
(test scores, report and presentation upload etc.)
- Subject webpage: www.ara.bme.hu/oktatas/tantargy/NEPTUN/BMEGEATAM06
- Laboratory webpage (materials, control tools): www.ara.bme.hu/lab

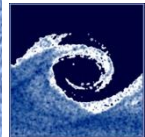

Work Safety!

A MUNKAVÉDELMI OKTATÁSON RÉSZTVENNI

Munkába állítani csak
olyan dolgozót szabad,
aki az elméleti és gyakorlati
oktatáson részt vett és saját a
munkája során alkalmazni tudja.

KÖTELEZŐ !

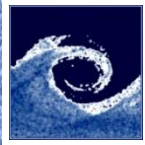

General information

- **Timetable:**

- 1st session: Measurement devices, measurement methods. Introduction to the measurement facilities, measurement uncertainty
- 2nd session: A measurement, B measurement
- 3rd session: Makeup measurements
- 4th session: A+B measurement presentations

(Details can be found in the syllabus)

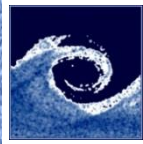

General information

Measurement groups:

- 4 students
- 2 measurement leaders for each measurement (A and B), the other 2 assist the measurement (attendance is obligatory!)
- The measurement leaders prepare one report and one presentation for the given measurement (same number of points will be given for both students)
- For each measurement a subtask is assigned. The members of the groups and the subtasks can be found on the webpage
- Example: Tomasics S. and Novotni G. did their measurement in section B (2nd measurement). They did measurement 5 with subtask E.

Mérőcsoport beosztás:				Mérés száma:	Feladat
1	A	Bálint Zádor	(az A jelű méréseken mérésvezető)	8	A
	A	Rácz-Szabó Lilla	(az A jelű méréseken mérésvezető)		
	B	Tomasics Sára	(a B jelű méréseken mérésvezető)	5	E
	B	Novotni Gergely	(a B jelű méréseken mérésvezető)		

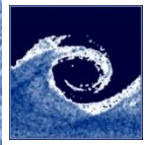

Preparing for the laboratory measurements

- In preparing for the laboratory measurements, all members of the measurement group must read the syllabus and understand the measurement which is to be made.
- A **hand written** outline of the measurement needs to be prepared by the lab leader. This outline should contain the following:
 - The measurement group's information (names, neptun codes), leaving a space for checking attendance
 - Space where the measurement supervisor can sign each page.
 - A list of the instruments which will be used during the measurement, leaving room for the serial numbers, which will be documented during the measurement
 - Tables for documenting the measured and calculated values, including atmospheric conditions (e.g. atmospheric pressure and temperature, etc.)
 - The equations which are necessary in order to complete the measurement and the associated calculations, leaving room for verification calculations.
 - Millimeter paper needs to be brought to the laboratory measurements

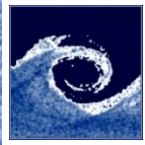

During the laboratory measurement

- At the beginning of the laboratory the hand written outline will be checked by the instructor supervising the measurement, and questions will be asked in order to determine whether the group is prepared for the measurement.
 - If the group is unprepared, they will be sent away
- The measurements need to be completed during the allotted time.
- The digital manometer needs to be calibrated during the laboratory measurement, with the help of the Betz micro manometer.
- During the measurement, department personnel supervising the measurements will assign a task to each group, by which some values measured during the laboratory measurement will be drawn on the millimeter paper, in order to check the correctness of the measurement and the understanding of the measured results. If the task can not be completed in a satisfactory manner, the measurements must be repeated.

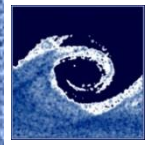

After the laboratory measurement

- A measurement report must be produced from the measured data
- Laboratory calculations must be checked utilizing the departments online evaluation tools.

www.ara.bme.hu/lab

- **Use of the control tools is mandatory.** The control tools only evaluate whether the equations were applied properly.
- **If the calculations were deemed invalid,** they must be repeated.
 - There is no limit as to the number of attempts which can be made, but the attempts are logged, and can be taken into account when giving grades. (fair use policy)
 - In previous semesters each measurement had students who were able to complete the calculations correctly upon their first attempt.
- **Once the calculations are correct,** a code is provided to the student.
 - **This code must be included on the laboratory report cover.**
 - The number of attempts, and the calculation error [%], as compared to the expected calculated value, will be taken into consideration when grades are assigned.

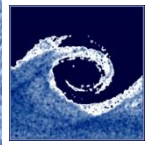

After the laboratory measurement

- Example:

Calculations are not accepted. Please check your data and try again!
Number of attempts: 1.

Measured and evaluated measurement data

* Atmospheric pressure:	99600	[Pa]
* Lab. temperature:	21.8	[°C]
Inflow coefficient:	skip	[-]
The diameter of the tube:	skip	[mm]
The diameter of the impeller:	skip	[mm]
Lab. temperature:	skip	[K]
Density of air:	skip	[kg/m ³]
* Kinematic viscosity of air:	0.000015	[m ² /s]
Error of pressure-difference measurement:	skip	[Pa]
Error of the temperature measurement:	skip	[K]
Error of atmospheric pressure measurement:	skip	[Pa]

Accepted!

The values for only one operating point should be given

* Number of revolution:	2500	[1/min]
* Pressure difference measured at the inlet orifice:	385	[Pa]
* Total pressure increase produced by the fan:	417	[Pa]
* Flowrate:	0.43387	[m ³ /s]
* Effective power:	205.7	[W]
* Flow coefficient:	0.1221	[-]
* Pressure coefficient:	0.358	[-]
* Absolut error of the effective power:	1.1763	[W]
* Relative error of the effective power:	0.0572	[-]

Accepted!

Inaccurate calculation result!

Inaccurate calculation result!

Accepted!

Inaccurate calculation result!

Inaccurate calculation result!

- It is not mandatory to fill out the grey cells..
- If the program deems the calculations incorrect, then it might be useful to fill out these cells, in order to help one find the source of the error.

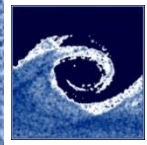

After the laboratory measurement

- After the calculations are accepted, the reports must be submitted through the poseidon network.
- Reports must be submitted by midnight of the second Sunday following the measurements.
- Consultations:
 - The faculty members grading the reports will provide one consultation opportunity per week for each measurement (one hour per measurement per week) they are grading. Consultation timetables can be found on the department website.
 - The measurement groups can also come to the laboratory to consult with the supervisors overseeing the given measurements during the last 15 minutes of any regular measurement session.

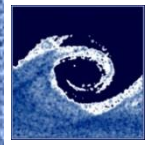

Requirements regarding the laboratory reports I.

- The cover of the laboratory report must be downloaded from the website.
- The lab report can only be 8 pages long plus the required report cover and mandatory annex
- The report should contain the following:
 - Code (proving that the calculations are right) on the cover
 - Short description of the measurement, data of the measurement device
 - The subtask
 - Equations
 - The measured and calculated data in tables
 - Uncertainty calculations
 - Necessary diagrams with uncertainty (error bars)
 - Interpretation of the measurement results
 - Bibliography

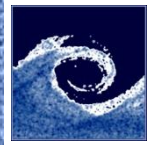

Requirements regarding the laboratory reports II.

- The calculations and tables used for making the diagrams (Excel) need to be submitted together with the report
- The diagrams need to be point diagrams (scatter plot, XY plot). The use of line diagrams is UNACCEPTABLE! (in this case the distances on the X axis will not be proportional)

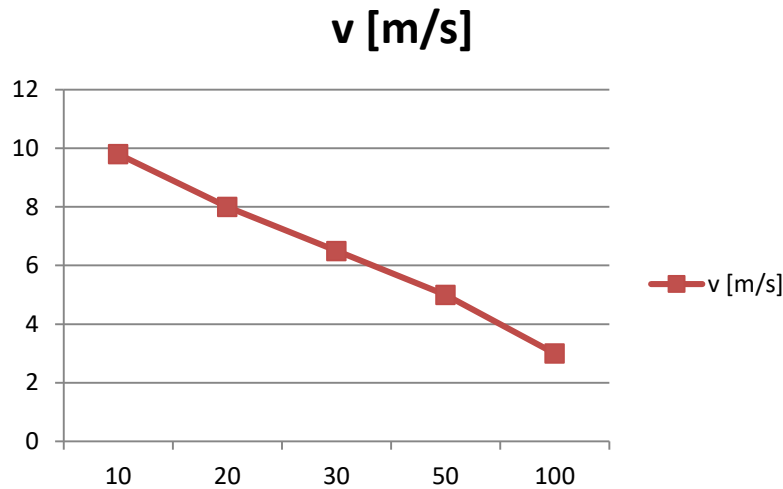

Unacceptable (and ugly)

(the values along the X axis are only considered as names or titles)

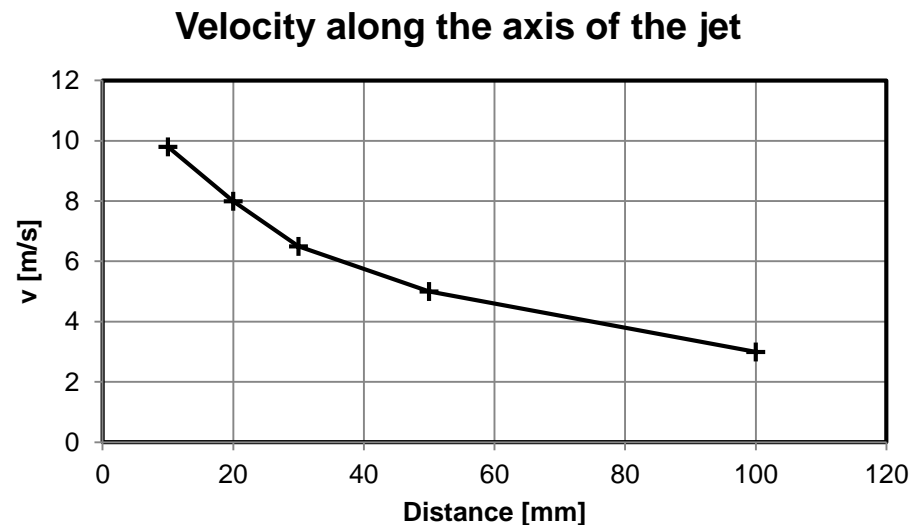

Acceptable

(the values along the X axis are considered as numbers)

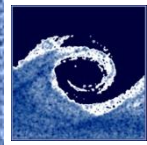

Requirements regarding the laboratory reports III.

UNACCEPTABLE AND UGLY DIAGRAM

Budapesti Műszaki és Gazdaságtudományi Egyetem

Áramlástan Tanszék[®]

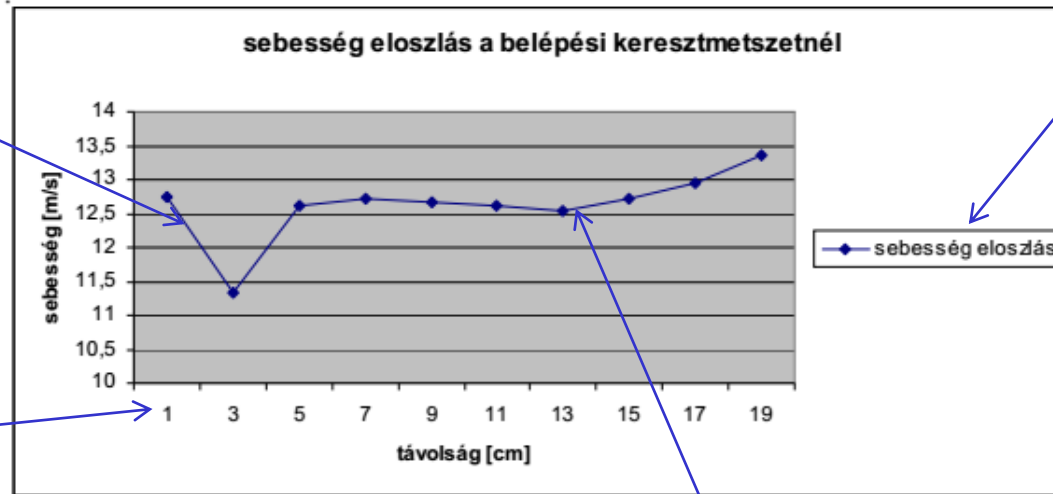

Mindkét helyen számoltunk átlagsebességet is a $v = \frac{\sum v_i}{n}$ képlet segítségével, ahol $n=10$. Ez alapján a kilépésnél 10,997 m/s, a belépésnél pedig 12,626 m/s az átlag sebesség.

The curve does not need to be colored. Why is a grey background used?

The type of diagram used is unacceptable

Unnecessary use of space. This makes the diagram small. Since there is only one set of data, it is even more so unnecessary.

The use of a frame is unnecessary

The uncertainty is not marked

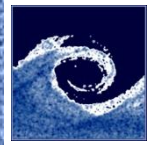

Requirements regarding the laboratory reports IV.

AN ACCEPTABLE DIAGRAM

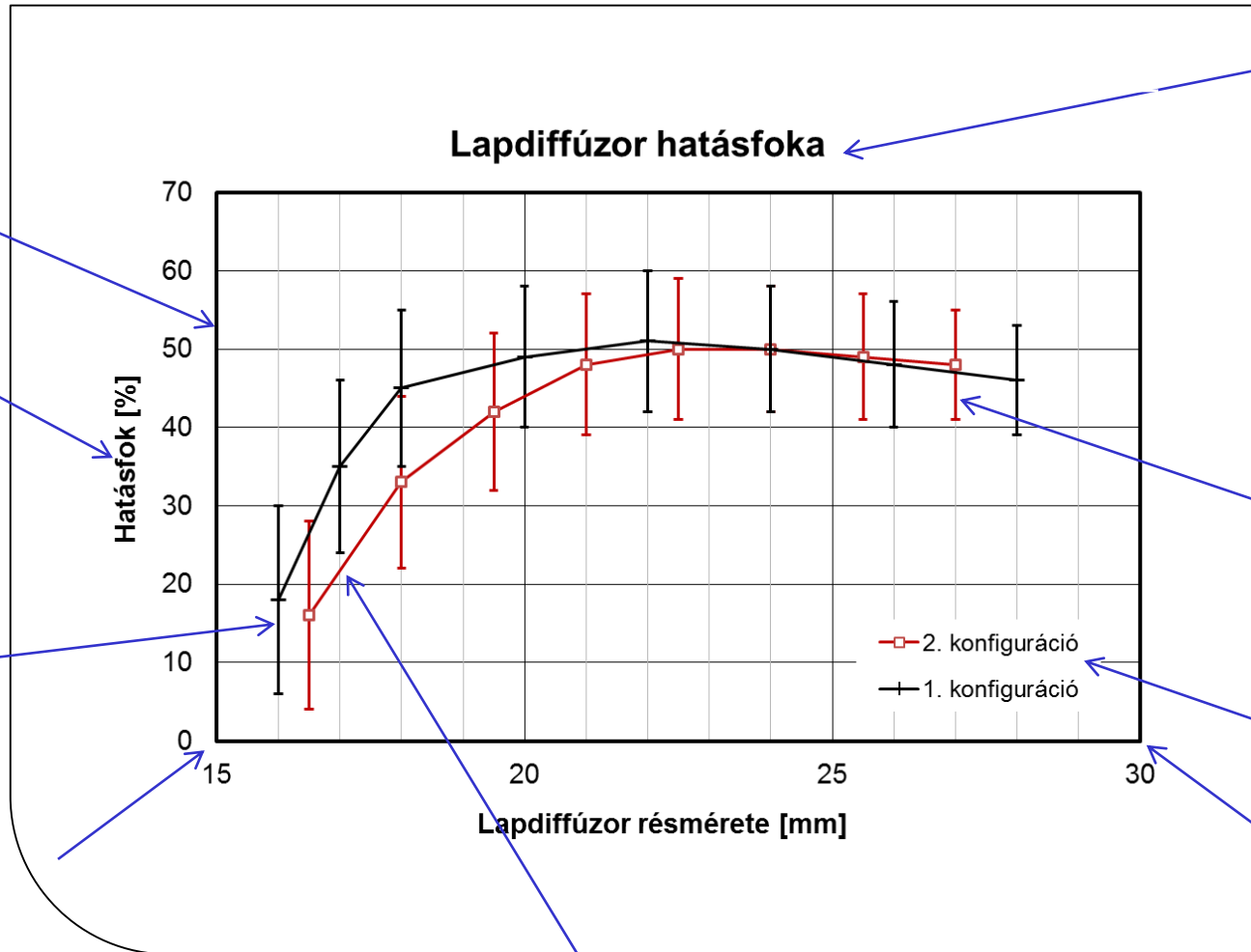

Diagram title
(not always necessary, since one can also make use of the description of the diagram below it)

Minimum number of contrasting colors

Logical key

The diagram is not miniature, but rather uses all the space provided

Points are connected using straight lines
(we are not interpolating between the points, but rather connecting those points which belong together. This is not always necessary)

Frame: 1.5-2 pt, main divisions: 0.5 pt.

Named axis and [units]

Letters should be of legible size

Measurement uncertainty (Error bars)

The axis starts from 0. (Do not use autoscale, unless it is necessary for correctly visualizing the

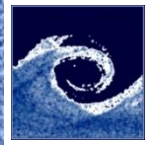

Requirements regarding the laboratory reports V.

- The report should be logical and „nice”
 - Justified form
 - Equations are created with the equation editor and not copied in as a picture
 - Diagrams are uniform
 - Hand made figures should be avoided (use: photos, CAD softwares...)
 - EXCEL: use scatter plot, XY plot.
- The file extension of the report should be PDF
- A mandatory annex to the 8 pages needs to contain the following:
 - A scanned copy of the hand written notes which were signed upon completion of the laboratory measurement, and which contain all the tables of all the data which was recorded.
- **The uploaded zip file must contain an excel file in which the calculations were made and the pdf of the laboratory report.**
- The name of the file should be in the following form:
 - Lastname1_neptun1_lastname2_neptun2_Mx_deadline.zip
 - Example: Tomasics_ABC123_Novotni_DEF456_M5E_20161106.zip

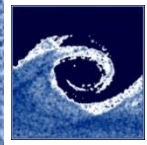

After the laboratory measurement

- ALL LABORATORY REPORTS NEED TO BE ORIGINAL AND MADE BY THE LAB GROUP! ANY MEASUREMENT LEADERS SUBMITTING WORK WHICH WAS NOT SOLELY PRODUCED BY THE GROUP, WITHOUT CITING THE APPROPRIATE SOURCE, WILL BE REPORTED TO THE DEAN'S OFFICE AND THE ETHICS COMMITTEE IN ACCORDANCE WITH THE RULES OF THE TVSz.
- The reports are evaluated within 2 working days, and a message is sent to the student through the poseidon network informing the student whether the report was accepted or not.
- A report can be resubmitted once for a better grade. The submission needs to be made by the third Sunday at midnight.
- If the report is unacceptable, there are two more opportunities for resubmitting the report. If the second opportunity is needed, then a fine must be paid. The deadline of the first opportunity is the third Sunday at midnight.
- The report is **accepted** if the received points reach the **40%** of the maximal points
- An accepted report is a criterion of the presentation
- Please note that in some cases the reports need to be submitted earlier in order to make sure that presentations can be presented when needed.

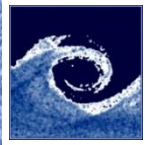

Presentation

- An example of a typical presentation, can be downloaded from the webpage.
- 8 minutes per presentation
- The measurement needs to be summarized.
- The personal measurement assignment needs to be presented and explained.
- The measurement stand and the used equipment needs to be presented.
- Measurement uncertainty calculations need to be presented.
- The evaluation of the results needs to be presented.
- The results need to be shown
- The conclusions and results need to be summarized.
- **Try to make it unique and interesting!**

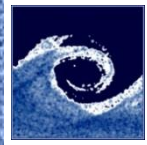

Late submission and make up

- Sanctions for late submission
 - -20% and a fine must be paid
 - At the latest, the report must be submitted by Friday at 12:00 on the 14th week! (this is a very severe delay)
- Make up of the presentation:
 - On the make up week (15th week)
 - A fine is charged

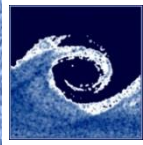

Checklist

At the measurement:

- In preparing for the measurement (hand written measurement plan): assignment, neptun code, name, documentation, personal assignment, mm paper, signature. CHECK
- The laboratory instructor checks your preparedness with 1 or 2 questions CHECK
- Record atmospheric conditions (p_0 , T_0) before and after the laboratory CHECK
- Calibrate to the Betz micro manometer CHECK
- You can ask questions from any of the laboratory instructors at the laboratory session, but it is advised to ask from the one leading your measurement
- Check the list of supplies in your measurement box. The box will be opened and closed by the laboratory instructor. The laboratory instructor will provide manometers, and will replace those which need to be charged. Do not connect digital manometers to chargers!

Consultation

- Consultations can be made with the appropriate instructor during consultation hours. (prior to the measurements (!) you can also turn to the fluid mechanics student group)
- Calculation results need to be checked www.ara.bme.hu/lab
- Once calculations are correct and the report is complete, submit the report: www.ara.bme.hu/poseidon (pdf+xls)
- file name = Lastname1_neptun1_lastname2_neptun2_Mx_deadline.zip



Determining the uncertainty of the results (error calculation) I.

- **Absolute error** (measurement uncertainty): the region within which the measurement data is located.
- Notation if the measured data is X : δX
- The **correct specification of the measurement data** in this case: $X \pm \delta X$
- **Relative error**: $\delta X / X$
- In case of a **calculated quantity (R)** the error propagates, and the following equation is used:

$$R = R(X)$$

$$\delta R = \frac{\partial R(X)}{\partial X} \cdot \delta X$$

- **In case of multiple, independently measured variables :**

$$R = R(X_1, X_2, \dots, X_n)$$

$$\delta R = \sqrt{\sum_{i=1}^n \left(\frac{\partial R(X_i)}{\partial X_i} \cdot \delta X_i \right)^2}$$

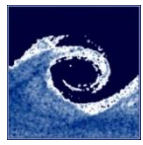

Determining the uncertainty of the results (error calculation) II.

Example: Velocity measurement uncertainty

Dynamic pressure measured using a Pitot-static (Prandtl) tube:

$$\Delta p_d = 486.2 \text{ Pa}$$

Atmospheric conditions experienced in the lab:

$$p_0 = 1010 \text{ hPa} \quad ; \quad T = 22^\circ\text{C} \quad (293\text{K});$$

Specific gas constant of air

$$R = 287 \text{ J/kg/K}$$

$$v = \sqrt{\frac{2}{\rho_{air}} \cdot \Delta p_d} \quad \rho_{air} = \frac{p_0}{R \cdot T}$$

$$v = \sqrt{\frac{2}{p_0} \cdot \Delta p_d R T}$$

$$v = f(T, p_0, \Delta p_d, \text{const. values})$$

$$v = 28.55 \frac{\text{m}}{\text{s}} \quad \rho_{air} = 1.2 \frac{\text{kg}}{\text{m}^3}$$

Quantities having uncertainties (X_i):

- The measurement uncertainty of the atmospheric pressure comes from the error arising when reading the scale: $\delta p_0 = 100 \text{ Pa}$
- The measurement uncertainty of the atmospheric temperature in the lab: $\delta T = 1 \text{ K}$
- The pressure measurement uncertainty arising when making a measurement using a Pitot-static (Prandtl) probe and a EMB-0XY digital manometer: $\delta(\Delta p_i) = 2 \text{ Pa}$

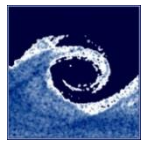

Determining the uncertainty of the results (error calculation) III.

Example: Velocity measurement uncertainty

Typical calculation of absolute error:

$$\delta R = \sqrt{\sum_{i=1}^n \left(\delta X_i \cdot \frac{\partial R}{\partial X_i} \right)^2} \quad \rightarrow \quad \delta v = \sqrt{\sum_{i=1}^n \left(\delta X_i \cdot \frac{\partial v}{\partial X_i} \right)^2}$$

$$R = v$$

$$X_1 = T; X_2 = p_0; X_3 = \Delta p_d$$

(δp , δT , $\delta(\Delta p_d)$)

$$v = \sqrt{\frac{2}{p_0} \cdot \Delta p_d R T}$$

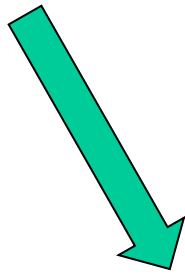

$$\left\{ \begin{array}{l} \frac{\partial v}{\partial T} = \sqrt{2R} \cdot \frac{1}{2} \cdot T^{-\frac{1}{2}} \cdot \frac{1}{\sqrt{p_0}} \cdot \sqrt{\Delta p_d} = 0,0484 \frac{m}{s \cdot K} \\ \frac{\partial v}{\partial p_0} = \sqrt{2R} \cdot \sqrt{T} \cdot \frac{-1}{2} \cdot p_0^{-\frac{3}{2}} \cdot \sqrt{\Delta p_d} = -1,4 \cdot 10^{-4} \frac{m}{s \cdot Pa} \\ \frac{\partial v}{\partial \Delta p_d} = \sqrt{2R} \cdot \sqrt{T} \cdot \frac{1}{\sqrt{p_0}} \cdot \frac{1}{2} \cdot \Delta p_d^{-\frac{1}{2}} = 0,029 \frac{m}{s \cdot Pa} \end{array} \right.$$

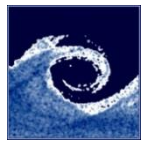

Determining the uncertainty of the results (error calculation) IV.

Example: Velocity measurement uncertainty

The absolute uncertainty of the velocity measurement:

$$\delta v = \sqrt{\left(\delta T \cdot \sqrt{\frac{2R}{p_0}} \Delta p_d \cdot \frac{1}{2} \cdot T^{-\frac{1}{2}} \right)^2 + \left(\delta p_0 \cdot \sqrt{2 \cdot R \cdot T} \cdot \Delta p_d \cdot \frac{-1}{2} \cdot p_0^{-\frac{3}{2}} \right)^2 + \left(\delta(\Delta p_d) \cdot \sqrt{\frac{2 \cdot R \cdot T}{p_0}} \cdot \frac{1}{2} \cdot \Delta p_d^{-\frac{1}{2}} \right)^2}$$

$$\delta v = 0.07739 \frac{m}{s}$$

$$v = 28.5497 \frac{m}{s}$$

Based on which:

The number of significant digits!
Max. 2 significant digits should be provided.

The relative uncertainty of the velocity measurement:

$$\frac{\delta v}{v} = 0.0027 = 0.27\%$$

The result of the velocity measurement:

$$v = 28.55 \pm 0.08 \frac{m}{s}$$

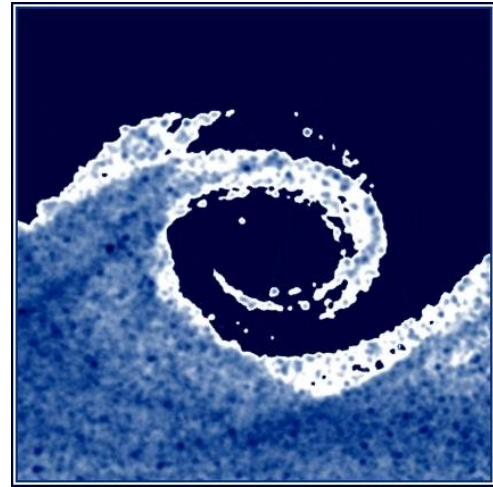

Budapesti University of Technology and Economics

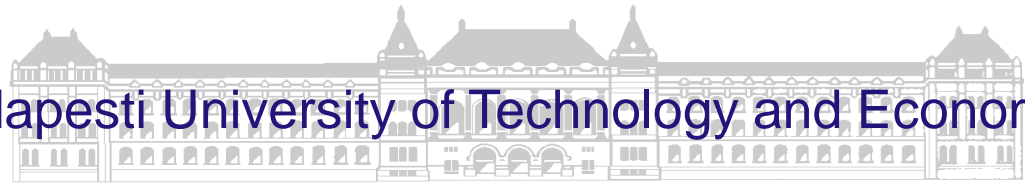

Department of Fluid Mechanics

www.ara.bme.hu

Pre-measurement class II.

Department administrator of measurements:
Dr. Csaba Horváth horvath@ara.bme.hu

2019.
spring

Department of Fluid Mechanics H-1111 Bertalan Lajos u. 4-6. „AE” building

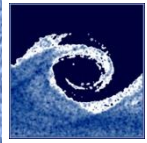

Summary of the measurement process

- Successful measurement midterm exam
- Download and read the measurement syllabus
- Hand made measurement plan
- Measurement (preparation, measurement plan, millimeter paper are necessary)
- Prepare measurement report and excel file at home
- Check if your calculations were correct
- If the calculations are correct, upload the report and the excel (the deadline is midnight of the second Sunday following the measurement)
- Correct the report according to the comments
- Prepare a presentation (if the report was accepted)
- Upload the presentation
- Present

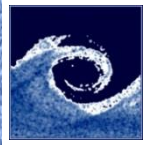

Measuring pressure differences (measuring Δp)

- Provides the basis of many measurements (e.g. velocity, volume flow rate)
- For a fluid medium, pressure differences can be measured between two points
- It is often measured with regard to a reference value (atmospheric pressure, static pressure in a duct)
- Measurement instruments
 - U tube manometer
 - Betz manometer
 - Inclined micro manometer
 - Bent tube micro manometer
 - EMB-001 digital handheld manometer

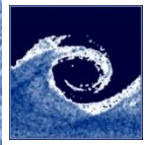

Measuring Δp / U tube manometer I.

- Pipe flow
- Butterfly valve
- Average of the pressure measured on the pressure taps around the perimeter

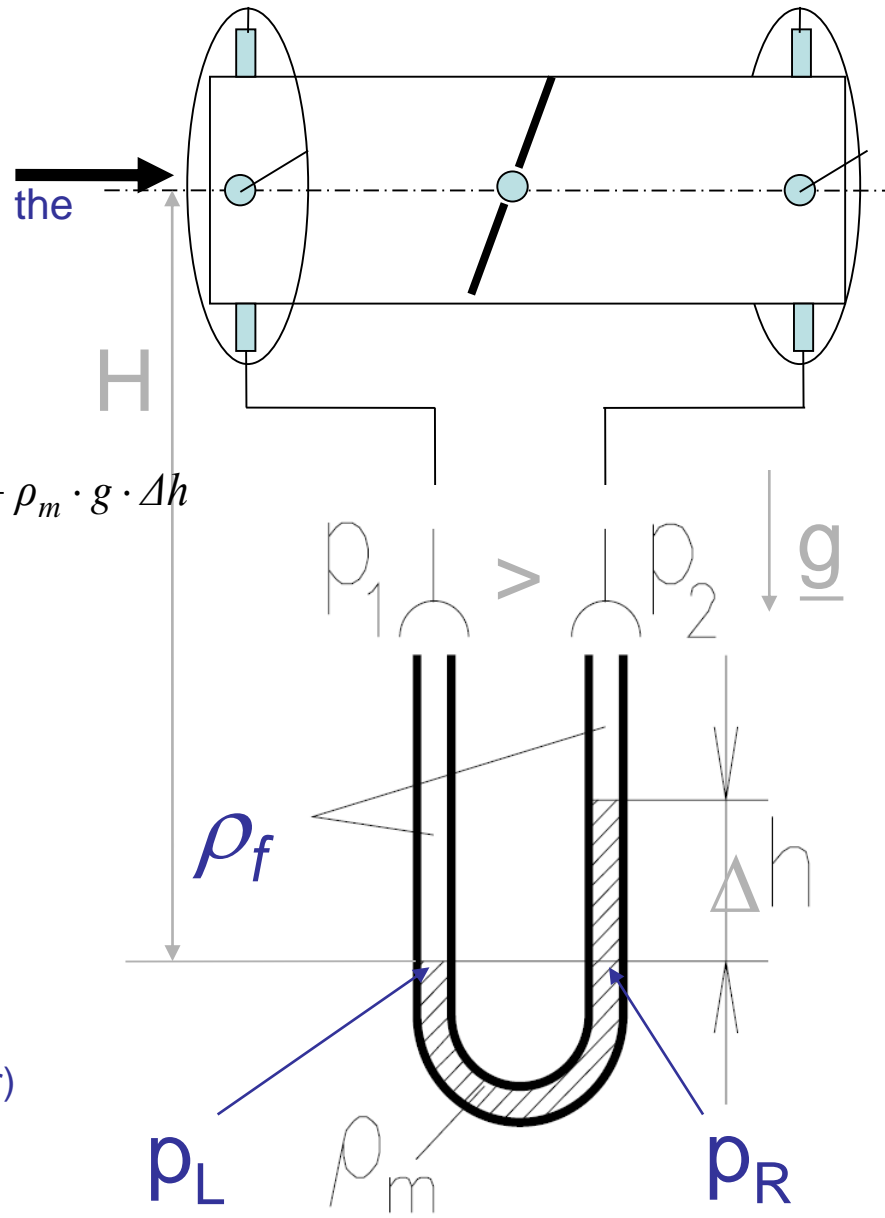

The manometers balance equation:

$$p_L = p_R$$

$$p_1 + \rho_f \cdot g \cdot H = p_2 + \rho_f \cdot g \cdot (H - \Delta h) + \rho_m \cdot g \cdot \Delta h$$

$$p_1 - p_2 = (\rho_m - \rho_f) \cdot g \cdot \Delta h$$

Can be simplified if

$$\rho_f \ll \rho_m$$

(e.g. if the measured fluid is air

and the measurement fluid is water)

$$p_1 - p_2 = \rho_m \cdot g \cdot \Delta h$$

Notice that

$$\Delta p \neq f(H)$$

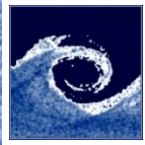

Measuring Δp / U tube manometer II.

The manometers balance equation:

$$\Delta p = (\rho_m - \rho_f) g \Delta h$$

Density of the measuring fluid ρ_m (approximately)

$$\rho_{Hg} \approx 13600 \frac{kg}{m^3} \quad \text{mercury}$$

$$\rho_{water} \approx 1000 \frac{kg}{m^3} \quad \text{water}$$

$$\rho_{Alcohol} = 830 \frac{kg}{m^3} \quad \text{alcohol}$$

Density of the measured fluid: ρ_f (For example air)

$$\rho_{air} = \frac{p_0}{R \cdot T} = 1.19 \frac{kg}{m^3}$$

p_0 - atmospheric pressure [Pa] $\sim 10^5$ Pa

R - specific gas constant for air 287 [J/kg/K]

T - atmospheric temperature [K] ~ 293 K = 20°C

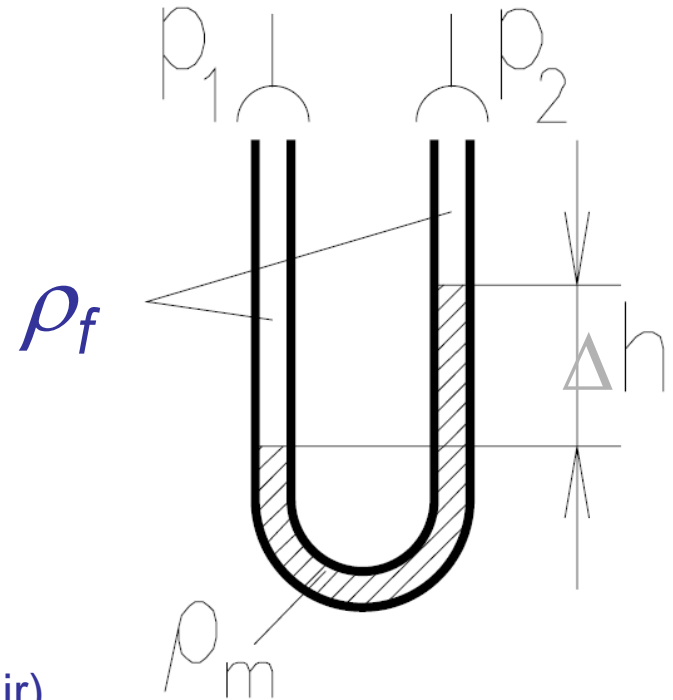

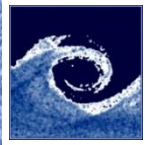

Measuring Δp / U tube manometer III.

Example: the reading: $\Delta h = 10mm$

The accuracy $\sim 1mm$: The absolute error:

$$\delta(\Delta h) = \pm 1mm$$

How to write the correct value with the absolute error(!)

$$\Delta h = 10mm \pm 1mm$$

The relative error:

$$\frac{\delta(\Delta h)}{\Delta h} = \frac{1mm}{10mm} = 0.1 = 10\%$$

Disadvantages:

- Reading error (need to make two measurements)
- Accuracy $\sim 1mm$
- For a small pressure difference, the relative error is large

Advantages:

- Reliable
- Does not require servicing

Measuring Δp / upside down U tube micro manometer

The manometer's balance equation

$$p_1 - p_2 = (\rho_{water} - \rho_{air}) \cdot g \cdot h$$

Since in most cases upside down U tube manometers are used to measure liquid (e.g. water) filled lines, the measurement fluid is usually air, and the density ratio is therefore (1.2/1000). ρ_a (density of air) can be neglected.

The advantage of this measuring device is that when it is used for liquid filled systems, air can be used instead of mercury in order to improve the accuracy of the relative error of the readings!

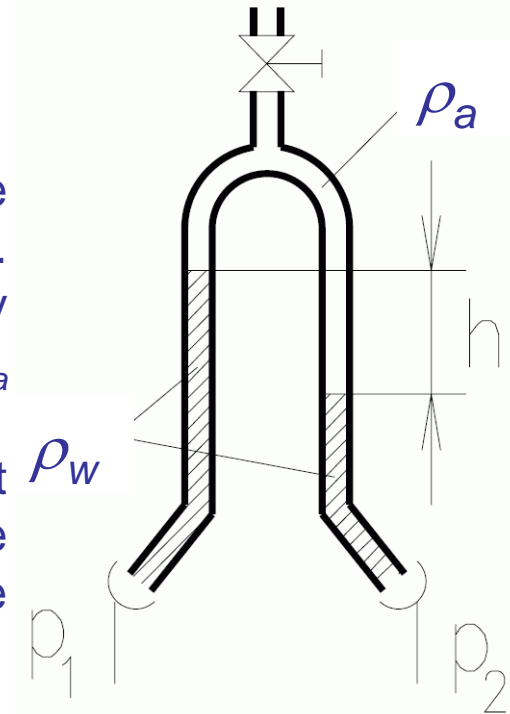

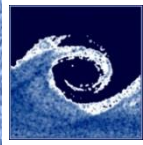

Measuring Δp / Betz micro manometer

The relative error is reduced by optical means, improving the accuracy.

Accuracy $\sim 0,1\text{mm}$: The absolute error is:

$$\Delta h = 10\text{mm} \pm 0.1\text{mm}$$

The relative error:

$$\frac{\delta(\Delta h)}{\Delta h} = \frac{0.1\text{mm}}{10\text{mm}} = 0.01 = 1\%$$

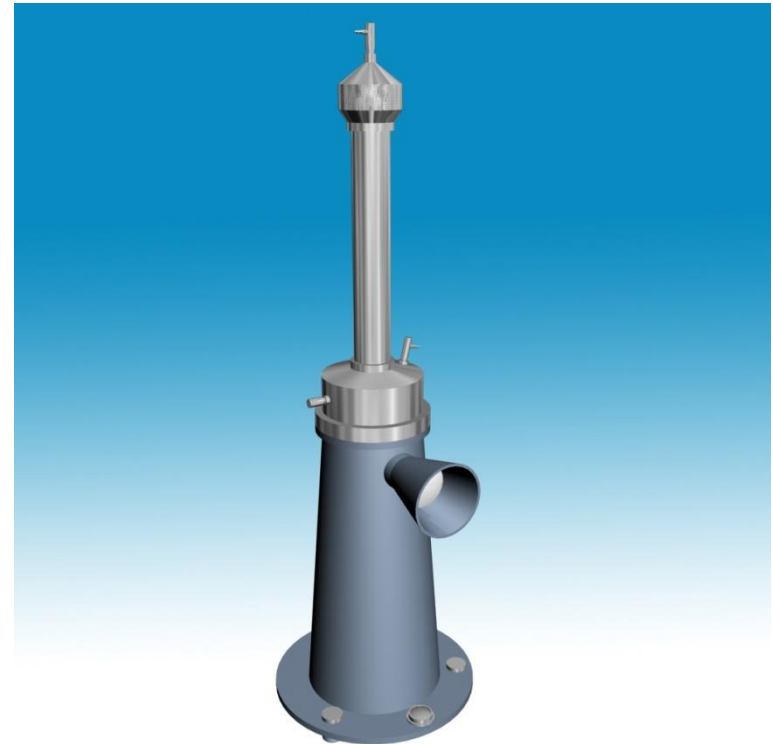
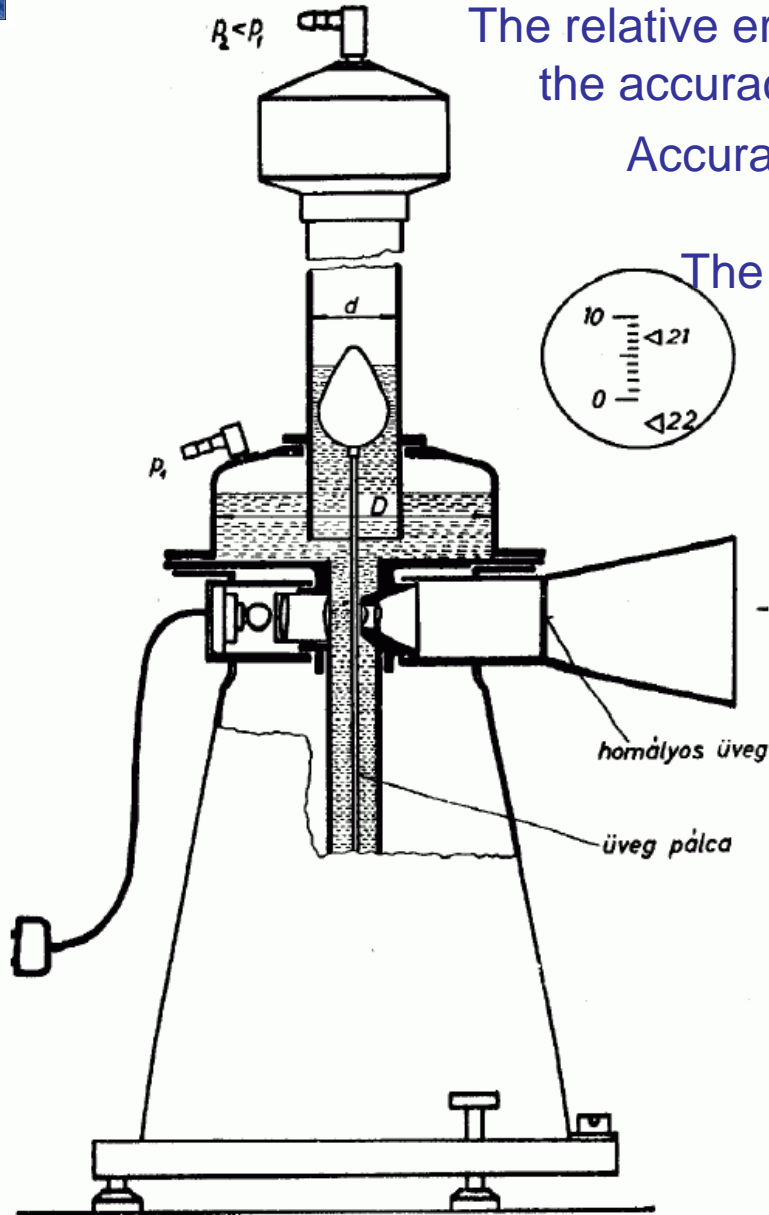

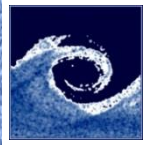

Measuring Δp / inclined micro manometer

The manometers balance equation

$$p_1 - p_2 = \rho_m \cdot g \cdot \Delta h$$

$$\Delta h = L \cdot \sin\alpha$$

Accuracy: $\delta L \sim \pm 1\text{mm}$,

Relativ error in the case of $\alpha=30^\circ$

$$\frac{\delta L}{L} = \frac{\delta L}{\frac{\Delta h}{\sin\alpha}} = \frac{1\text{mm}}{\frac{10\text{mm}}{\sin 30^\circ}} = 0.05 = 5\%$$

The relative error is a function of the inclination angle - $f(\alpha)$ - It is characterized by a changing relative error.

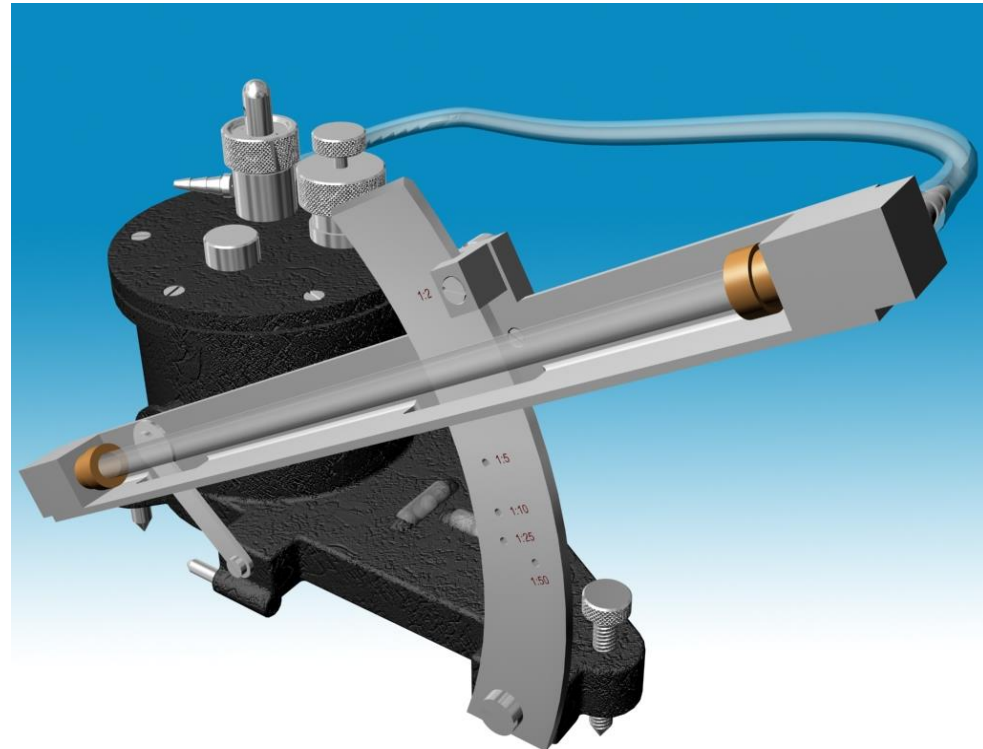
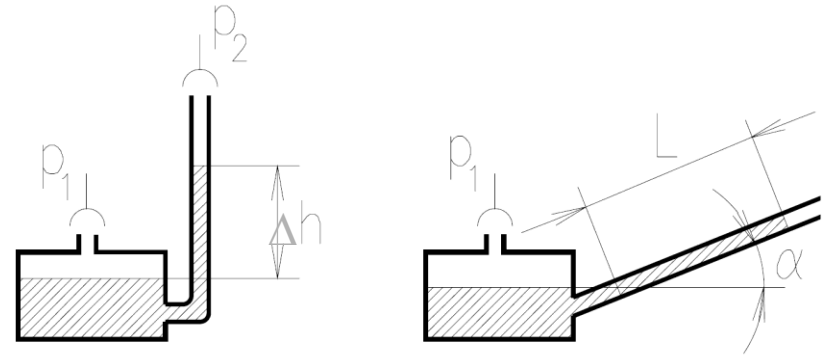

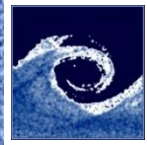

Measuring Δp / bent tube micro manometer

Is characterized by a
constant relative error
and a nonlinear scale

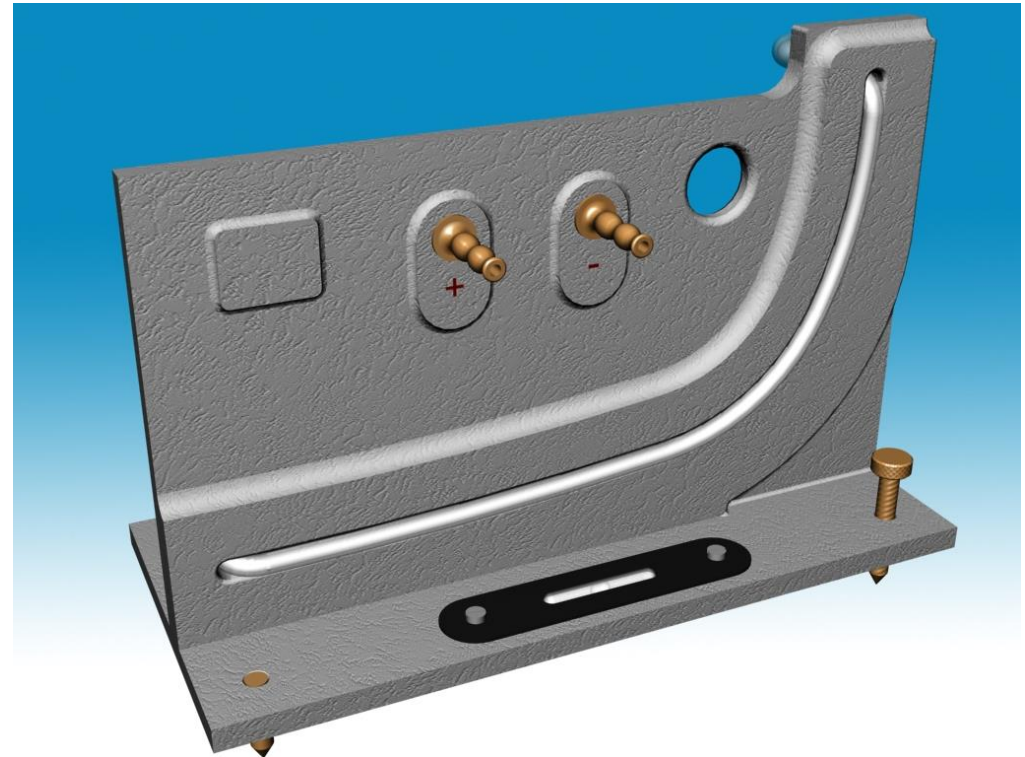
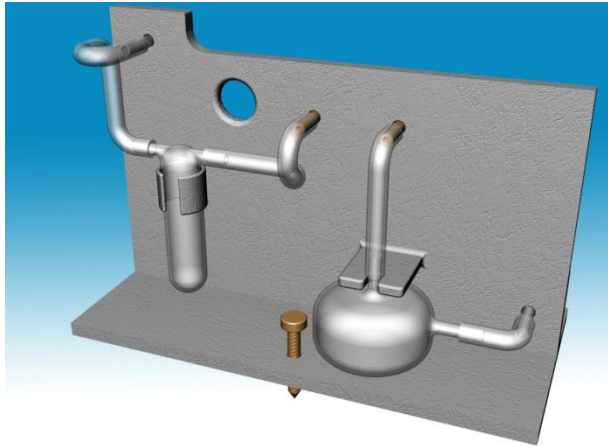

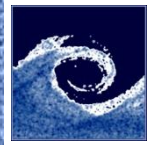

Measuring Δp / bent tube micro manometer

Is characterized by a constant relative error and a nonlinear scale

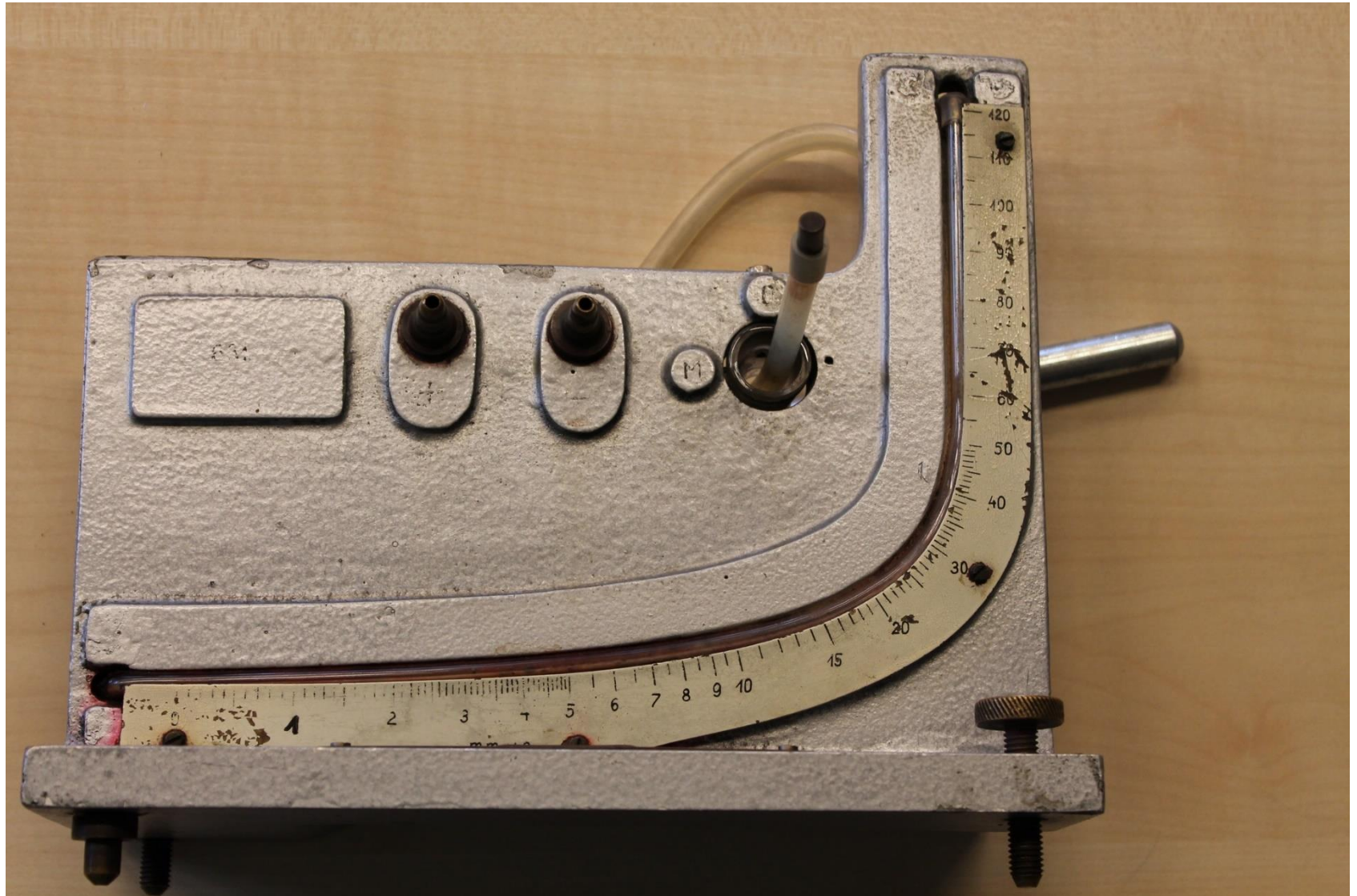

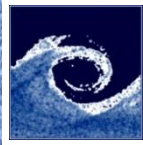

Measuring Δp / EMB-001 digital manometer

List of buttons to be used during the measurements

On/Off	Green button
Factory reset	„0” followed by the „STR Nr
Changing the channel	„CH I/II”
Setting 0 Pa	„0 Pa”
Averaging time(1/3/15s)	„Fast/Slow” (F/M/S)

Measurement range:

$$\Delta p = \pm 1250 Pa$$

Measurement error:

$$\delta \Delta p = 2 Pa$$

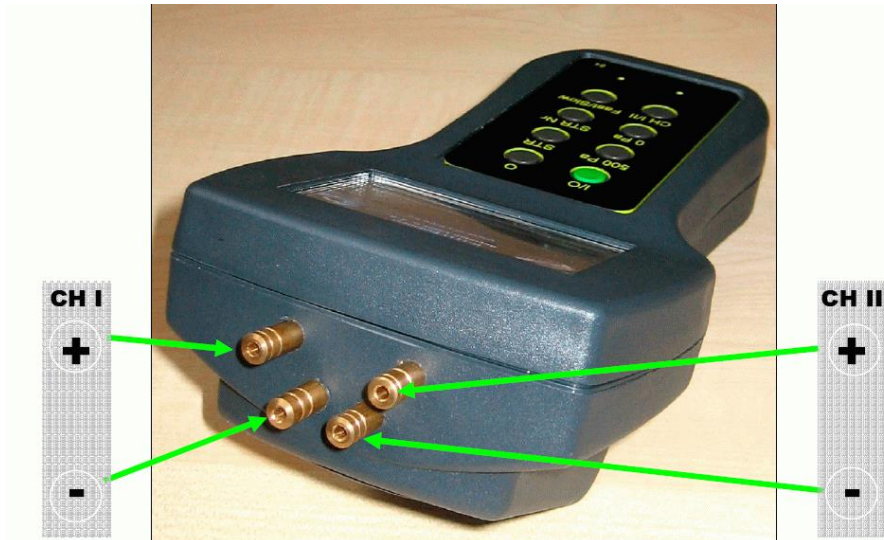

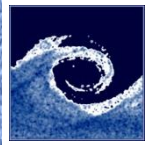

Measuring Δp / EMB-001 digital manometer

Calibration of the EMB-001 digital manometer (obligatory!):

- The digital manometer is compared to a more accurate instrument: the **Betz micro manometer**
- A **regression line** will be used for the calibration
- This can be done by a linear trend line in Excel. The values measured with the digital manometer should be on the horizontal axis, and the values measured with the Betz manometer should be on the vertical axis. Both should be in Pa dimension.
- The accurate measurement values can be determined from the values measured with the digital manometer using the regression line.

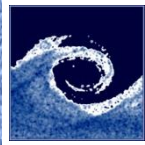

Measuring Δp / EMB-001 digital manometer

Calibration of the EMB-001 digital manometer: EXAMPLE

Atmospheric data:

t_0 [$^{\circ}\text{C}$]	25
T_0 [K]	298.15
ρ_w [kg/m^3]	997.1
g [N/kg]	9.81

Measured and calculated values:

p_{dig} [Pa]	p_{Betz} [w.c.mm]	p_{Betz} [Pa]
0	0.0	0.0
102	10.2	99.8
200	20.0	195.6
303	30.3	296.4
401	40.0	390.8
526	52.3	511.1

The diagram:

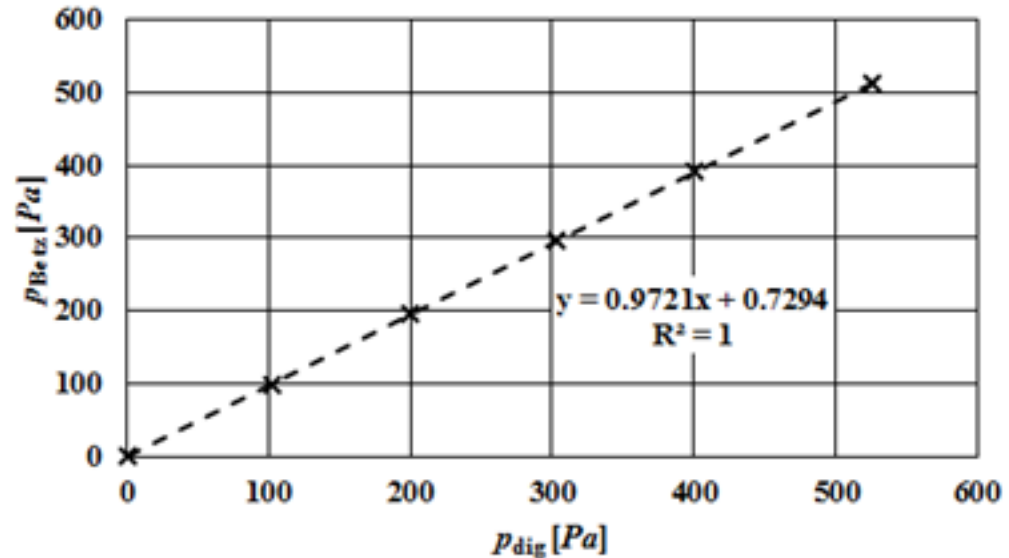

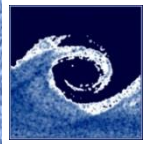

Measuring Δp / Pressure tap

When measuring pressures we need the streamlines to be parallel and straight

In this case the pressure is not changing perpendicularly to the streamlines

(The normal component of the Euler equation)

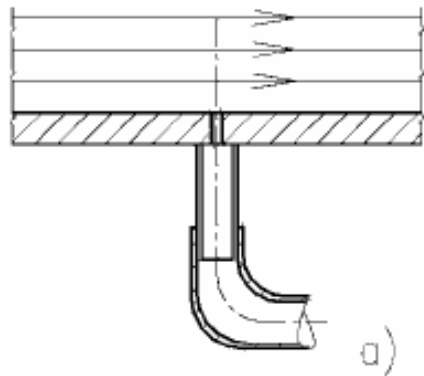

a)

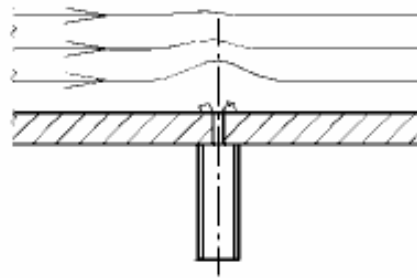

b)

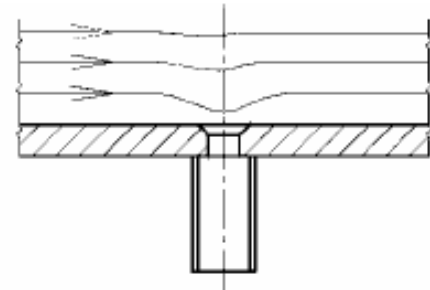

c)

a) Correct b) c) Incorrect

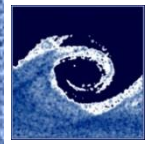

Velocity measurement devices

- Pitot tube/probe
- Pitot-static (Prandtl) tube/ probe

Theoretical background:

- Simple form of the Bernoulli equation for lossless flow:

$$p_1 + \rho \cdot U_1 + \frac{\rho}{2} \cdot v_1^2 = p_2 + \rho \cdot U_2 + \frac{\rho}{2} \cdot v_2^2$$

- If $U_1=U_2$ and $v_2=0$:

$$\frac{\rho}{2} \cdot v_1^2 = p_2 - p_1$$

$$v_1 = \sqrt{\frac{2}{\rho} (p_2 - p_1)}$$

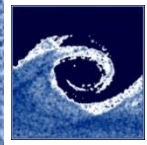

Velocity measurement / Pitot tube/probe

Pitot, Henri (1695-1771), French engineer.

Determining the dynamic pressure:

$$p_d = p_t - p_{st}$$

p_t the pressure measured in the stopped fluid (total pressure)

p_{st} the pressure acting on a surface which is parallel to the flow (static pressure)

$$p_d = \frac{\rho_f}{2} \cdot v^2$$

Determining the velocity:

$$v = \sqrt{\frac{2}{\rho_f} \cdot p_d}$$

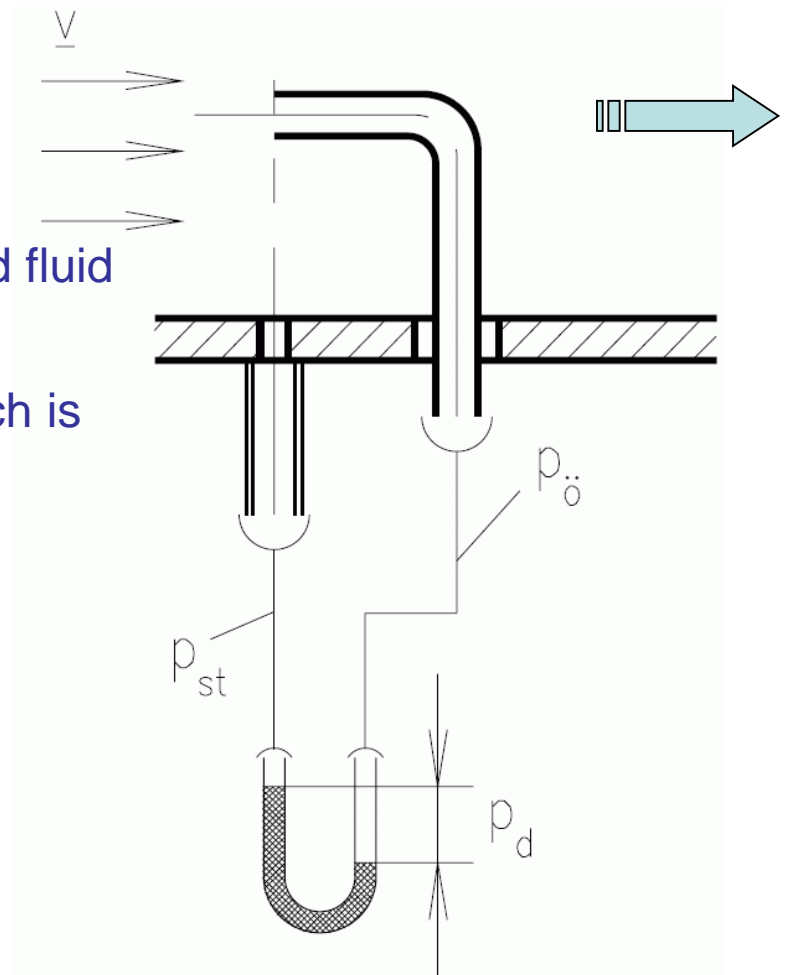

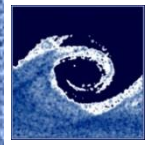

Velocity measurement / Pitot-static (Prandtl) tube/probe

Prandtl, Ludwig von (1875-1953), German fluid mechanics researcher

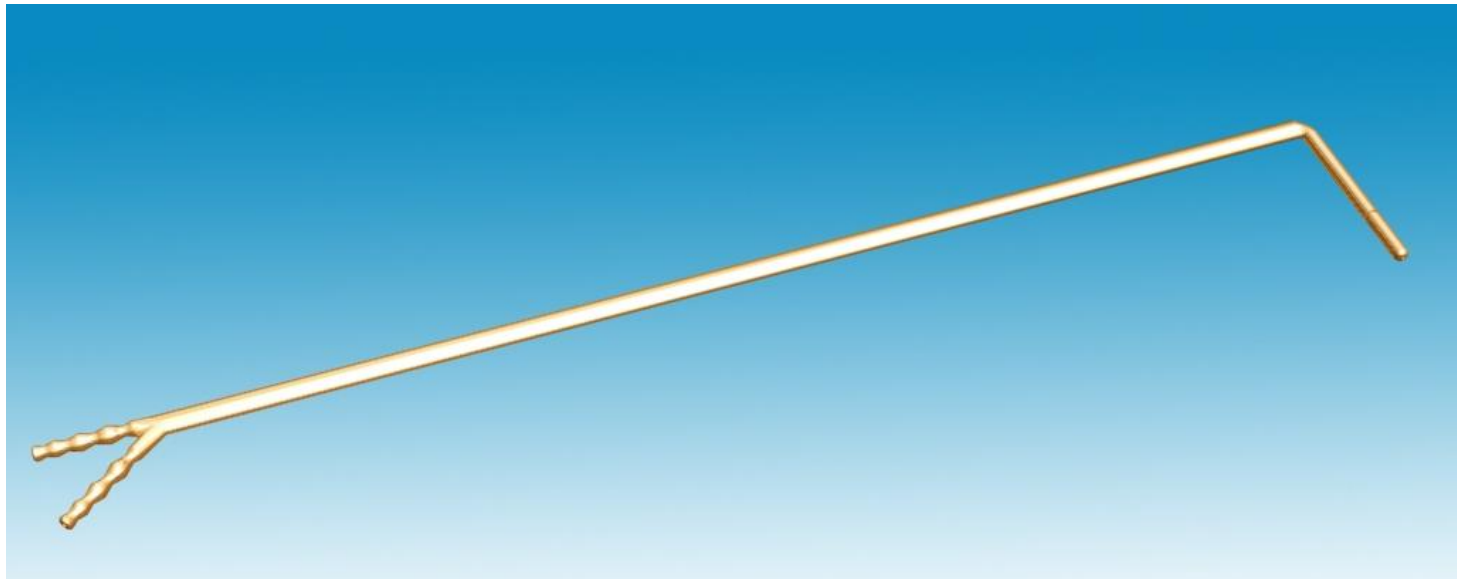
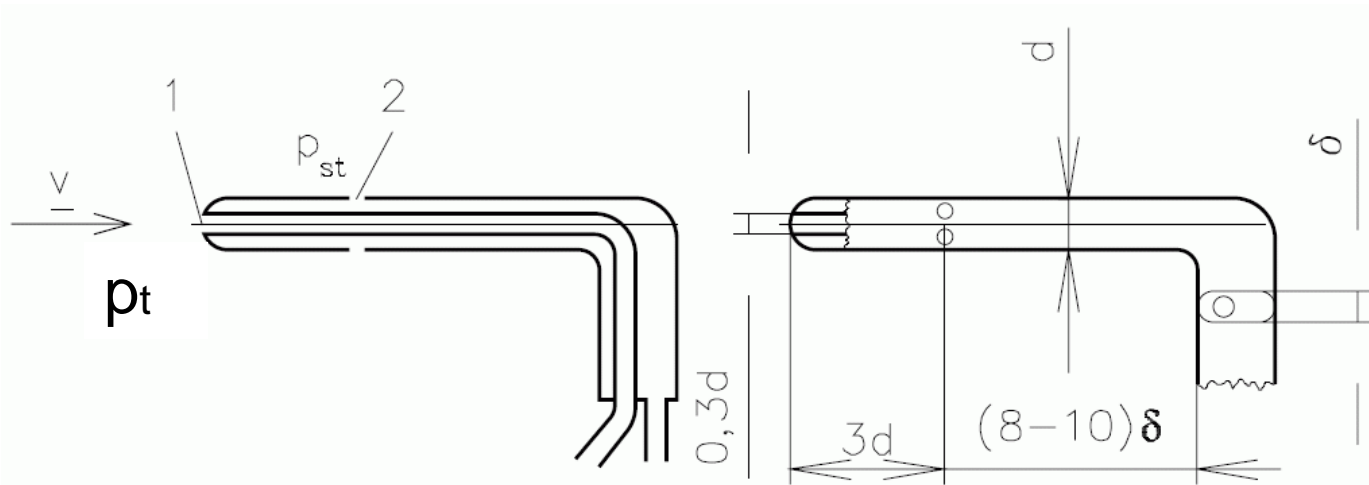

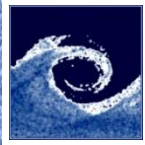

Measuring volume flow rate

- Definition of volume flow rate: the volume of fluid which passes through a given surface per unit time. Usually it is the basis of accounting or system control
- It is denoted by : q_v , its dimension is: *volume / unit time* (e.g.: m^3/s)
- Measurement method based on velocity measurements in multiple points
 - Non-circular cross-sections
 - Circular cross-sections
 - 10 point method
 - 6 point method
- Pipe flow meters based on flow contraction
 - Venturi flow meter (horizontal/inclined axis)
 - Through flow orifice (contraction ratio, iteration)
 - Inlet orifice
 - Inlet bell mouth

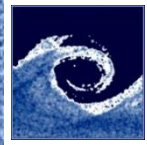

Volume flow rate / based on velocity measurements I.

Non-circular cross-sections

$$q_v = \int_A \underline{v} \cdot \underline{dA} \approx \sum_{i=1}^n v_{m,i} \cdot \Delta A_i$$

Assumptions:

$$\Delta A_1 = \Delta A_2 = \Delta A_i = \frac{A}{n}$$

$$q_v = \Delta A_i \cdot \sum_{i=1}^n v_{m,i} = \frac{A}{n} \cdot \sum_{i=1}^n v_{m,i} = A \cdot \bar{v}$$

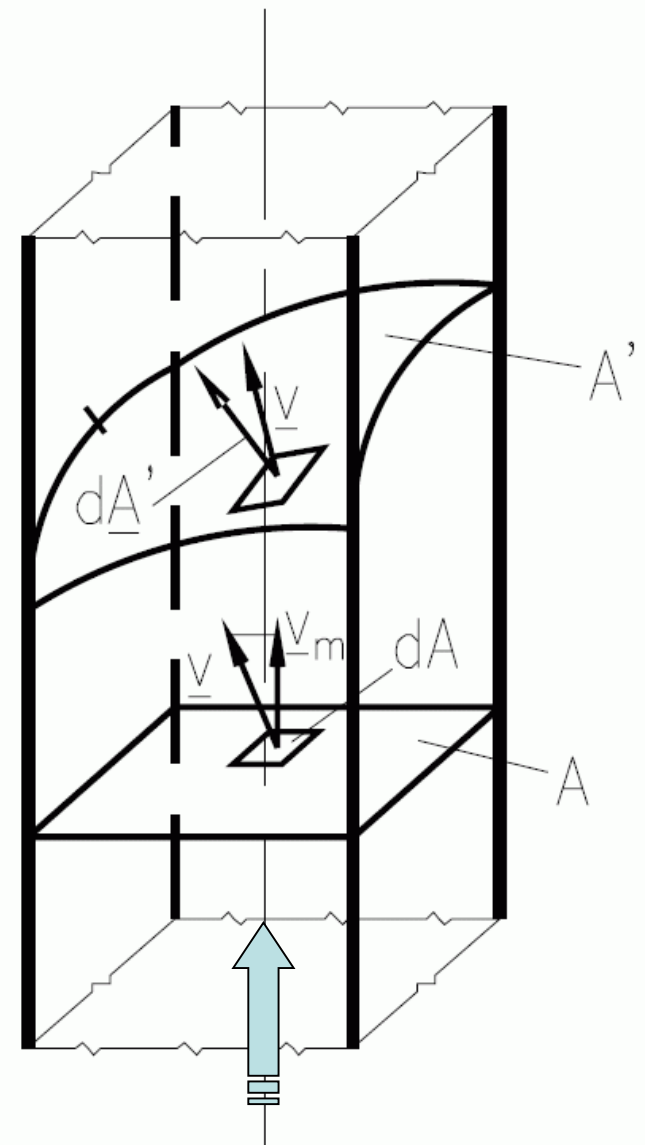
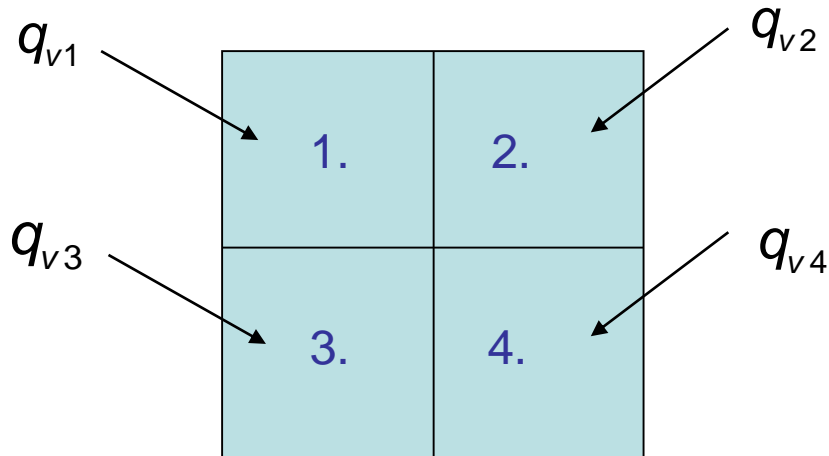

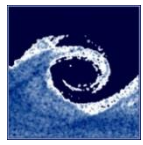

Calculating an average velocity from multiple velocity measurements

Very important: the square root of the averages \neq the average of the square roots(!)

Example: Measuring the dynamic pressure in multiple points and calculating the velocity from it

$$v_i = \sqrt{\frac{2}{\rho_f} \cdot \Delta p_i}$$

$$v_1 = \sqrt{\frac{2}{\rho_f} \cdot \Delta p_1}$$

1.	2.
3.	4.

$$\bar{v} = \frac{\sqrt{\frac{2}{\rho_{ny}} \cdot \Delta p_1} + \sqrt{\frac{2}{\rho_{ny}} \cdot \Delta p_2} + \sqrt{\frac{2}{\rho_{ny}} \cdot \Delta p_3} + \sqrt{\frac{2}{\rho_{ny}} \cdot \Delta p_4}}{4} \neq \sqrt{\frac{2}{\rho_{ny}} \cdot \frac{\Delta p_1 + \Delta p_2 + \Delta p_3 + \Delta p_4}{4}}$$

Correct

Incorrect

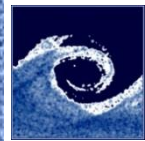

Volume flow rate / based on velocity measurements II.

Circular cross-sections, 10 point (6 point) method

- The velocity profile is assumed to be a 2nd order parabola
- Steady flow conditions
- Based on Pitot-static (Prandtl) tube measurements of the dynamic pressure

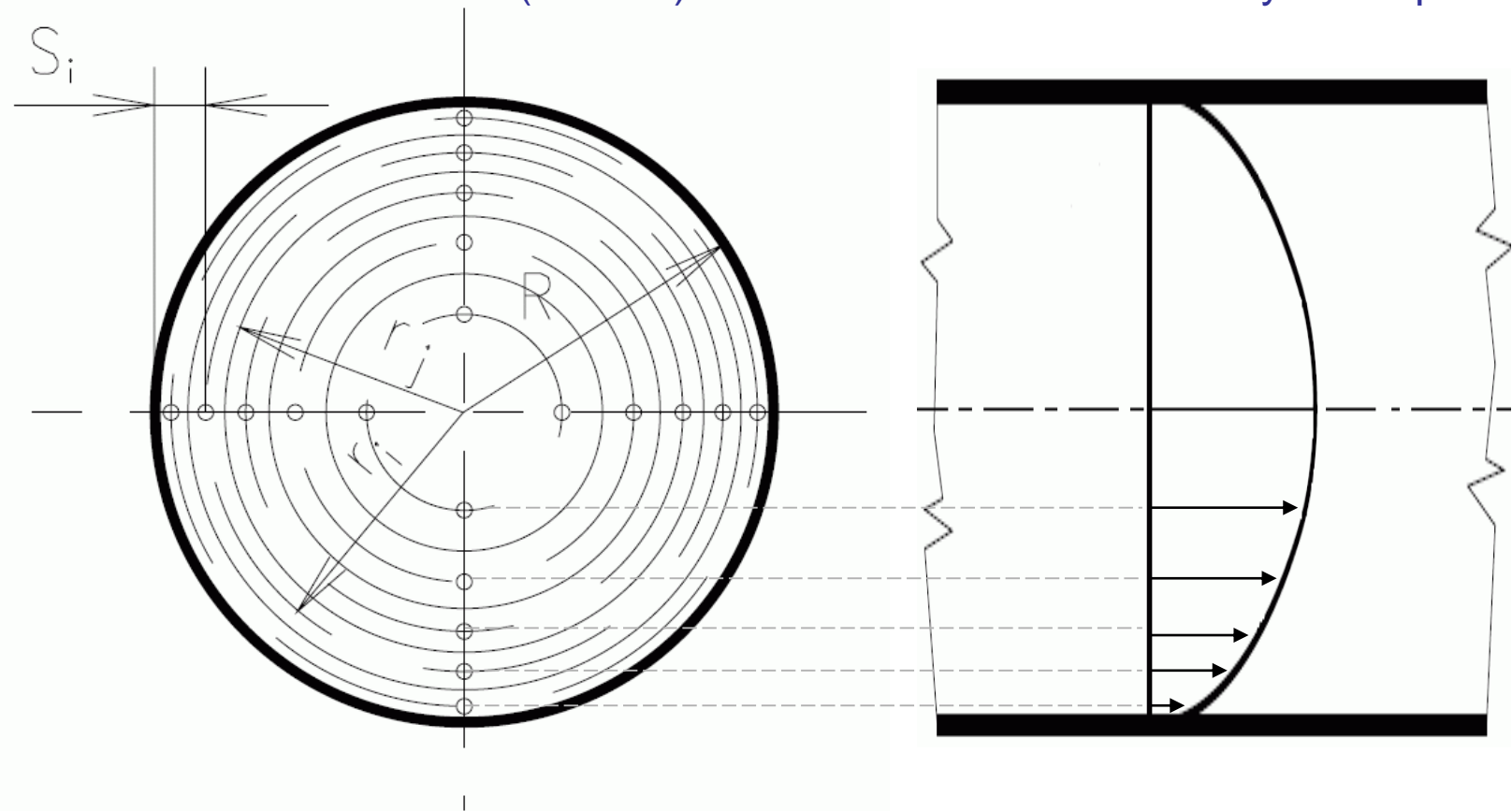

This is a standardized procedure, and the measurement point are given in the standard (MSZ 21853/2):

$S_i/D = 0.026, 0.082, 0.146, 0.226, 0.342, 0.658, 0.774, 0.854, 0.918, 0.974$

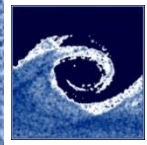

Volume flow rate / based on velocity measurements III. Circular cross-sections, 10 point (6 point) method

$$q_v = A \cdot \frac{v_1 + v_2 + \dots + v_{10}}{10}$$

Assumptions:

$$A_1 = A_2 = \dots = A_{10}$$

The **advantage** of this method, as compared to methods based on flow contraction, is that the flow is not disturbed greatly, and therefore the operation point of the system is not altered, and it is easy to execute the measurements.

The **disadvantage** is that the error can be much larger with this method. For long measurements it is also hard to keep the flow conditions constant. (10 points x 1.5 minutes = 15 minutes)

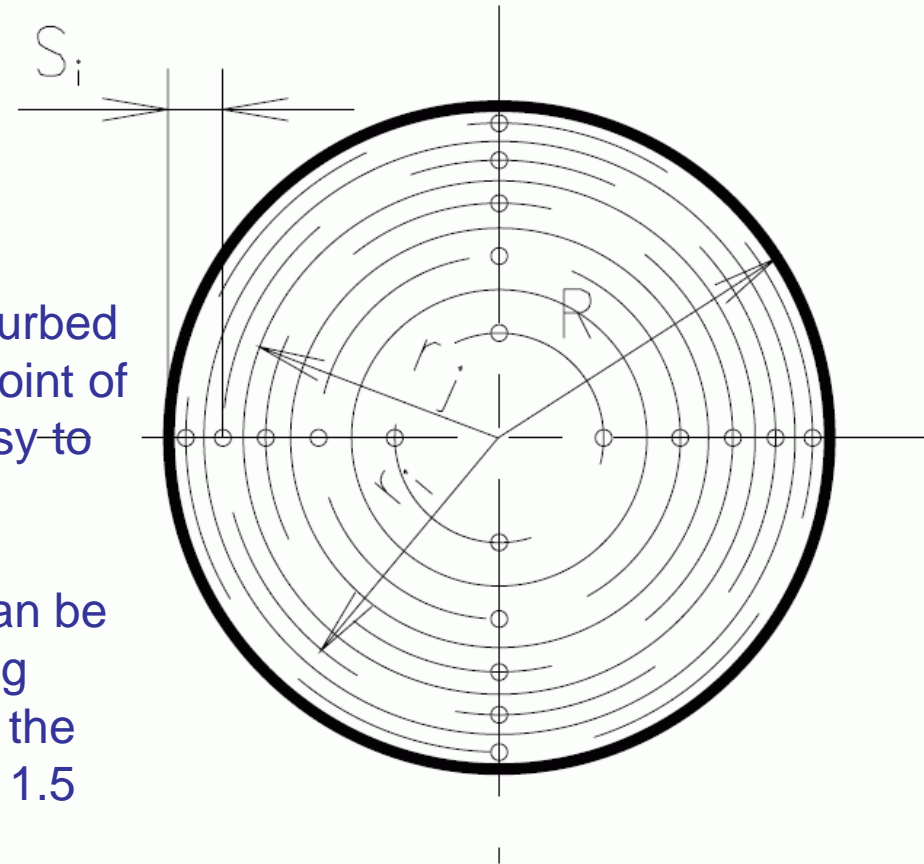

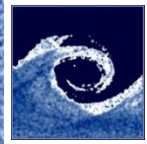

Volume flow rate / flow contraction methods

Venturi pipe

If compressibility is negligible
($\rho = \text{constant}$):

$$q_v = v \cdot A = \text{cont.} \quad [q_v] = \frac{m^3}{s}$$

$$q_v = v_1 \cdot A_1 = v_2 \cdot A_2$$

Bernoulli equation

($\rho = \text{const.}$, $U = \text{const.}$, no losses):

$$p_1 + v_1^2 \cdot \frac{\rho_f}{2} = p_2 + v_2^2 \cdot \frac{\rho_f}{2}$$

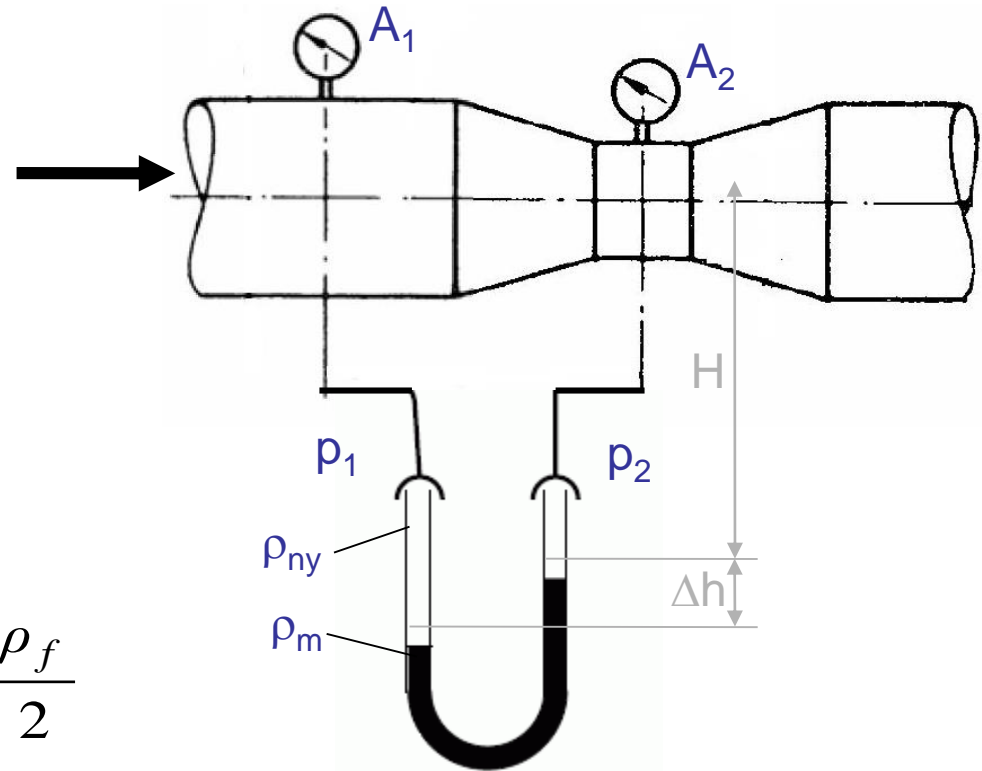

$$v_1 = \sqrt{\frac{(\rho_m - \rho_f) \cdot g \cdot \Delta h}{\frac{\rho_f}{2} \cdot \left[\left(\frac{d_1}{d_2} \right)^4 - 1 \right]}} = \sqrt{\frac{\Delta p}{\frac{\rho_f}{2} \cdot \left[\left(\frac{d_1}{d_2} \right)^4 - 1 \right]}}$$

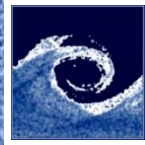

Volume flow rate / flow contraction methods

Through flow orifice

Standard orifice - pressure difference

$$\Delta p_{or} = p_1 - p_2$$

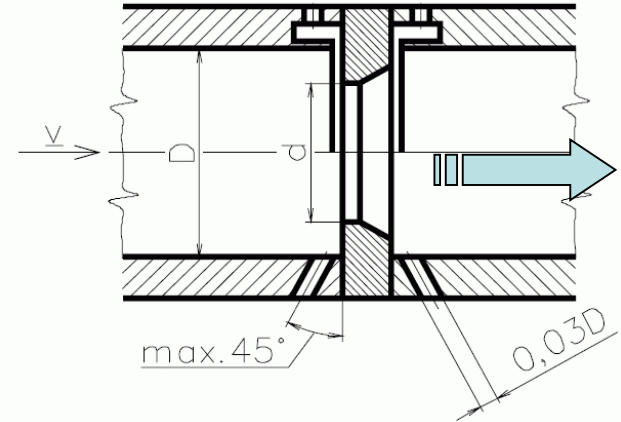
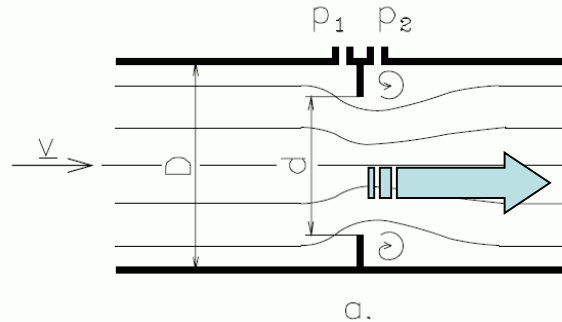

$$q_v = \alpha \cdot \varepsilon \cdot \frac{d_{or}^2 \cdot \pi}{4} \cdot \sqrt{\frac{2\Delta p_{or}}{\rho}}$$

- $\beta = d/D$ Cross-section ratio
- d [m] Diameter of the smallest cross-section
- D [m] Diameter of the pipe upstream of the orifice
- $Re_D = Dv/\nu$ Reynolds number's basic equation
- v [m/s] The average velocity in the pipe of diameter D
- ν [m²/s] kinematic viscosity
- p_1 [Pa] The pressure measured upstream of the orifice
- p_2 [Pa] The pressure measured downstream of the orifice
- ε Expansion number ($\varepsilon = \varepsilon(\beta, \tau, \kappa) \sim 1$ since for air, the change in pressure is small)
- α Contraction ratio, $\alpha = (\beta, Re)$ (When used according to the standard)
- κ Heat capacity ratio or Isentropic expansion factor
- $\tau = p_2/p_1$ Pressure ratio

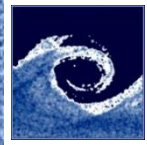

Volume flow rate / flow contraction methods

Inlet orifice (not standard)

Not a standard contraction – pressure difference

$$q_v = \alpha \cdot \varepsilon \cdot \frac{d_{or}^2 \cdot \pi}{4} \cdot \sqrt{\frac{2\Delta p_{or}}{\rho}}$$

$$\alpha = 0.6$$

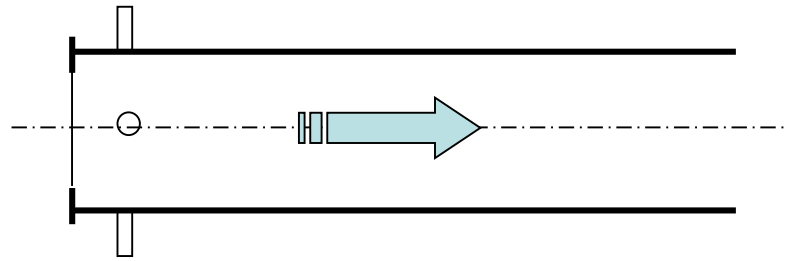

$$q_v = k \cdot \frac{d_{or}^2 \cdot \pi}{4} \cdot \sqrt{\frac{2\Delta p_{or}}{\rho}}$$

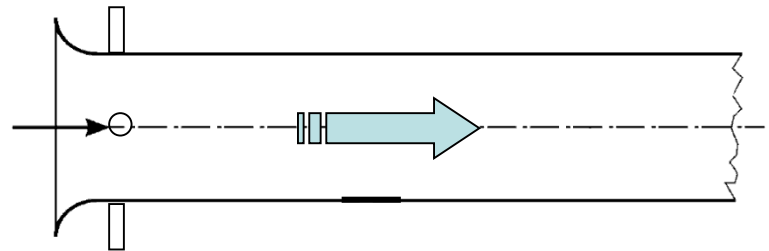

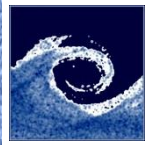

Comparison of volume flow rate measurement methods

ASPECT	CONTRACTION	VELOCITY-BASED
1/ Intrusiveness	" - " Considerable losses \Rightarrow the operating state may be modified \Leftrightarrow to be included already in the system design state	" + " Negligible intrusiveness (wall bores only)
2/ Following temporal changes in the operational state	" + " Follows unsteady flow rate continuously	" - " Does not follow (long-lasting surface integration) (\Leftrightarrow correction..?)
3/ Requirements	" - " Strict (manufacturing, installation, system is to be halted...)	" + " Moderate (no requirements, only recommendations, the system may run continuously...)
4/ Expenses	" - " High (manufacturing, installation, operation: losses to be covered)	" + " Moderate
5/ Accuracy	" + " High (limited uncertainty, guaranteed by the standard) <u>Legally defensible!</u>	" - " Moderate (limits of uncertainty are not guaranteed) <u>Legally assailable!</u>

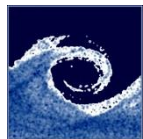

Thank you for your attention!