

M12

INVESTIGATION OF A RADIAL FAN

1. Objectives of the measurement, practical relevance

The objective of the measurement is the determination of the main characteristics of a radial fan with the help of measurements. The characteristic curves i.e. Δp_{total} total pressure increase as a function of volume flow rate q_v and the curves of effective power should be plotted for different rpm values. The flow characteristics on the suction side of the fan can be changed by the means of a pre-swirl element, therefore the effect on the fan efficiency can also be examined at a constant rpm.

In practice, fluids are transported by means of pumps, fans, blowers, or compressors. Among the numerous possible applications, it is worth mentioning, for example, the use of fans in the field of air conditioning, air supply/removal of fluegases from furnaces, or the cooling of electronics. An important characteristic of fans is that they supply a low total pressure rise ($\Delta p_{total} = 100-10000$ Pa). For a higher pressure rise blowers and compressors are used.

It is often necessary to determine the hydrodynamic properties of fans. An example of this would be when the design properties of newly developed machinery need to be verified. These measurements give an opportunity for the investigation of the cause of system malfunction by checking the working parameters of the given machine.

The present measurement gives an opportunity for the practical investigation of fans under laboratory conditions.

2. Description of the measuring system

Fan systems typically consist of a suction-pipe and a pressure pipe, a radial vane impeller used to supply the given total pressure rise, the fan housing and the electric motor used to drive the system. Depending on the flow incidence angle, axial, semi-axial, radial and cross-flow fans can be distinguished. In the case of radial fans, the flow enters into the housing parallel with the impeller axis and leaves radially perpendicular to it.

Changing the position of the working point of the fan on the characteristic curve (i.e. selecting different values for the Δp_{total} ; q_v pair), the effect on the effective power of the fan can be examined. In the same way, changes in the inlet guide vane angle can also be tested.

The whole measuring system consists of the following main parts:

- a radial fan mounted with a suction and pressure pipe;
- a variable speed electrical motor with a thyristor;
- an inlet guide vane with variable inlet angle;
- devices for examining the hydraulic properties of the fans: an inlet orifice with static pressure taps, a choke located on the pressure side.

The measuring device, looked at in the direction of the flow, consists of the following parts, as can be seen on **Fig. 1**

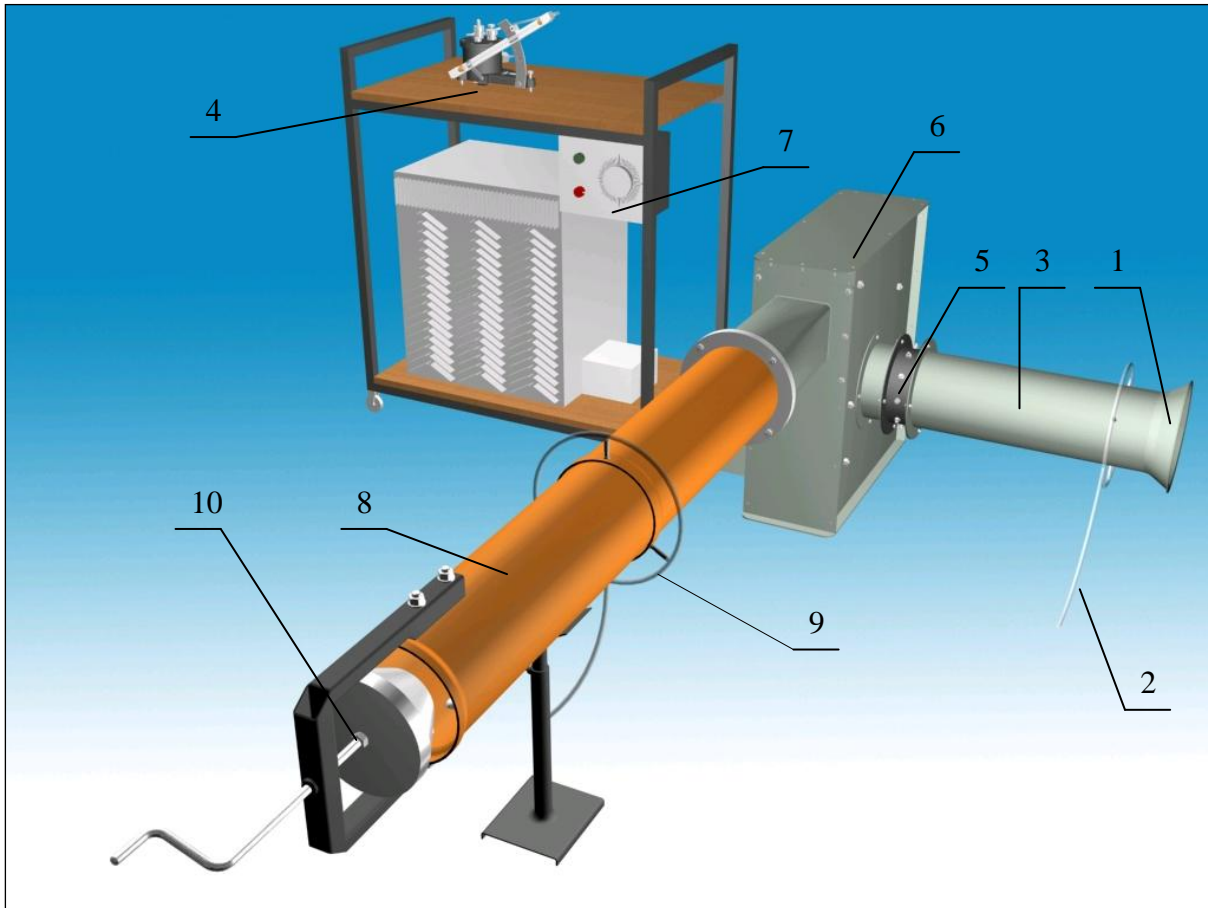

Fig.1 Measuring instrument

Legend:

1. Inlet orifice, used to measure volume flow rate.
2. Pressure measurement taps: Silicon-rubber tubes are connected to a small diameter hole located right after the inlet cone. The volume flow rate can be computed from the static pressure measured here.
3. Suction tube which leads the air into the inlet guide vane
4. Leaned- and curved micro manometers or digital pressure manometers. See reference [3] and [5]
5. Inlet guide vanes.
6. The radial fan.
7. Triphase asynchronous motor, controlled by a thyristor.
8. Pressure tube leading the air out of the fan.
9. Pressure measurement ports on the suction and pressure sides of the fan for determining the static pressure difference.
10. Adjustable choke at the end of the pressure tube. This is important when setting the different work points of the ventilator.

Beside the basic measuring system described above, other auxiliary devices are also needed. These are the barometer, thermometer, tape-measure and revolution counter.

3. Detailed description of the measurement process, essential experimental- and evaluation considerations

The characteristic curves have to be measured and plotted ($\Delta p_{total}; q_v$) for multiple rpm values, and then for every measurement point the effective power of the fan needs to be calculated.

The rpm can be kept constant by using the thyristor. The rpms are measured by a handheld tachometer, at the end of the motor shaft.

The rpms need to be checked for every working point, being that in a highly choked state the rpm can change. The different working points of the different volume flow rates are set by changing the hydraulic resistance of the pressure tube, i.e. by changing the horizontal position of the choking element. For every working point, the volume flow rate and the total pressure increase have to be measured. Plotting the different q_v and Δp_{total} value pairs that belong together for the different working points of the fixed rpm values will result in characteristic curves. The set of characteristic curves, which are plotted for the different $n = \text{constant}$ rpm values, should be presented in one common diagram together with the effective power data. Moreover, the characteristic curves belonging to one prescribed rpm value, showing the effect of the inlet guide vane on the effective power, should be plotted together in the same way as stated above.

3.1 Preparing for the measurement

First of all, before beginning the measurement, the working conditions of the measuring device need to be carefully examined. Second of all, the angle of the inlet guide vane should be set to a given angle and the pressure measurement ports should be connected. When measuring the volume flow rate, the pressure measurement ports located right after the inlet cone, should be carefully connected to the “negative” manometer port using the silicone rubber tubes. The other “positive” pressure port is left open to atmospheric pressure, i.e. it should be left unconnected. For further information regarding pressure measurement devices, see sources [2] and [3]. The static pressure difference between the pressure and suction side of the fan can be measured by connecting the manometer's ports directly to the measurement ports located at the fans end of the suction- and pressure tubes. This way the static pressure difference can be directly read.

After everything is carefully set, the fan, and therefore the measurements, can be started. If the displayed pressure values show a quasi-steady state (disregarding some small deviation around the mean value), the pressure values can be recorded. For a good characteristic curve, at least 10 working points are needed. Taking into consideration the nature of the measurements, the number of measurement points should be less than fifteen. The rpm of the fan should be measured at every working point and if the rpm changes, it should be corrected manually using the thyristor.

The first working point of every measurement should be taken at a maximum volume flow rate (the pressure tube choke is fully open), for the remaining points the volume flow rate should be lowered in 10% increments.

It can be seen in section 3.2 that the square root of the pressure is in a linear relationship with the volume flow rate or in other words the square of volume flow rate is linearly proportional to the pressure. In this way, setting the volume flow rate to 90% of its peak value, means that the pressure measured at the inlet orifice should be set to 81% of the value belonging to the maximum volume flow rate.

The characteristic curve of the fan can be determined from the following values:

- pressure drop measured at the inlet cone: Δp_{io}
- volume flow rate: q_v
- static pressure difference between the pressure- and suction side: $p_{st,pressure} - p_{st,suction}$
- effective power of the fan: P_{eff}

3.3 Calculation of the volume flow rate

The value of the volume flow rate is determined with the help of an inlet orifice, which is connected to the suction tube of the fan. From the pressure difference measured here, q_v can be computed as follows:

$$q_v = k \frac{d^2 \pi}{4} \sqrt{\frac{2 \Delta p_{io}}{\rho_{air}}} \quad (1)$$

where:	q_v [m ³]	- volume flow rate
	k [-]	- experimentally determined, $k=0.96$
	d [m]	- the diameter of the suction tube after the inlet cone
	Δp_{io} [Pa]	- the pressure drop of the inlet orifice (measuring cross section)
	ρ [kg/m ³]	- density of the fluid
	p_{atm} [Pa]	- atmospheric pressure
	R [J/kgK]	- specific gas constant of the air ($R = 287$ J/kgK)
	T [K]	- absolute ambient temperature

For further details on volume flow rate measurements consult [2].

3.3 Calculation of the total pressure rise

The spaces between the impeller blades where the air flows are the so-called blade passages. These blades exert a dynamic force on the air particles i.e. they are deflected in the direction of revolution as they pass through the passages, increasing their kinetic energy. The amount of increase can be measured by measuring the total pressure rise between the suction- and pressure tubes.

Total pressure rise produced by the fan:

$$\Delta p_{total} = p_{total,pressure} - p_{total,suction} = \left(p_{st,pressure} + \frac{\rho_{air}}{2} v_{pressure}^2 \right) - \left(p_{st,suction} + \frac{\rho_{air}}{2} v_{suction}^2 \right)$$

$$\rho_{air} = \frac{p_0}{RT_0} \left[\text{kg/m}^3 \right] \text{ the density of the fluid.}$$

$$v_{pressure} = \frac{q_v}{A_{pressure}} \text{ and } v_{suction} = \frac{q_v}{A_{suction}} \text{ [m/s]}$$

$$P_{eff} = q_v \Delta p_{total}$$

where:

$p_{st, pressure}$ and $p_{st, suction}$ [Pa] are the static pressures that can be measured at the pressure and suction side of the fan

$v_{pressure} = q_v/A_{pressure}$ and $v_{suction} = q_v/A_{suction}$ [m/s] are the average flow velocities in the pressure and suction tubes.

3.4 The effective power of the fan

The effective power P_{eff} of the fan is the product of q_v , the volume flow rate, and Δp_{total} , the total pressure rise:

$$P_{eff} = q_v \cdot \Delta p_{total}$$

The effective power of the radial fan highly depends on the flow incidence angle that can be changed by a so-called inlet guide vane (Fig. 1, element No. 5). The inlet guide vane consists of eight small trapezoid shaped blades along the circumference of the suction tube.

The required flow swirl of the suction side flow can be changed by setting the proper angle for the blades. Setting the incidence angle is possible with these plates in such a way that the inlet guide vane should first be disassembled from the suction tube. After the screw-nut is loosened, every guide vane can be set to the same required angle.

3.5 The flow and pressure coefficients

The characteristics (q_v , Δp_{total} , Δp_{st}) of a fan are defined by multiple parameters for a given geometry. These parameters are: the D diameter of the impeller which represents the size of the machine, the n revolution, the ρ density and the μ viscosity of the fluid. It seems impossible to measure the connection between all variables one by one, and to record the results in a simple form. It is possible to decrease the number of variables by creating dimensionless groups. Two of the possible dimensionless groups are the flow coefficient and the pressure coefficient.

$$\text{Flow coefficient: } \Phi = \frac{q_v}{\frac{D^2 \pi}{4} u_2}, \quad \text{Pressure coefficient: } \Psi = \frac{\Delta p_{total}}{\frac{\rho}{2} u_2^2},$$

where:

D [m] - diameter of the impeller ($D=340\text{mm}$)

u_2 [m/s] - circumferential velocity of the outer diameter of the fan

In contrast to dimensional quantities which provide individual characteristic curves ($\Delta p_{\delta} = f(q_v)$; $P_h = f(q_v)$), the curves of the dimensionless numbers characterize a type, i.e. a group of machines with a specific geometry. If the effect of the Reynolds number is neglected, then it can be stated that this representation contains in one curve all the characteristic curves of the machines with different size (D) and revolution (n).

3.6 Evaluation of the results

Measurement results have to be summarized in the form of a technical report based on the requirements given in [4]. Information regarding the measurement methods and the theoretical background can be found in [2].

The report should contain the characteristic curves of the fan for the different rpm values, plotted in one common graph.

Moreover, another diagram should be plotted for the characteristic curves of the fan for different incidence angles, measured at one specific rpm value.

In every case the graphs should also contain the effective power curves.

Diagrams should also be made for the pressure coefficient as a function of the flow coefficient.

Measured data should also be summarized in a tabular format, listing the applied equations as well.

Results should be compared with available literature (for example [1], [2]).

Error propagation calculations

Error propagation calculations (absolute and relative error) should be performed for every working point of a specific characteristic curve. The resulting values should be presented in all the diagrams depicting the q_v - Δp_{total} and P_{eff} curves.

The error calculation should be carried out for the calculated value of P_{eff} , effective power, which depends on the total pressure rise and the volume flow rate. Using the notations from the error calculation handout:

Expression of the effective power: absolute error: relative error:

$$P_{eff} = q_v \Delta p_{total} \qquad \delta P_{eff} = \sqrt{\sum_{i=1}^n \left(\delta X_i \frac{\partial P_{eff}}{\partial X_i} \right)^2} \qquad \frac{\delta P_{eff}}{P_{eff}} = ?$$

Where: X_i are the measured quantities and the related measuring errors

$X_1 = p_0,$	error of the pressure measurement	$\delta p_0 = 100 \text{ Pa}$
$X_2 = T_0,$	error of the temperature measurement	$\delta T_0 = 1 \text{ K}$
$X_3 = \Delta p_{i0}, X_4 = \Delta p_{total}$	error of the EMB-001 type digital manometer	$\delta \Delta p = 2 \text{ Pa}$

All data subject to error in the measurements (X_i) should be included in the expression of Δp_{total} and q_v in forming the expression of P_h .

Errors resulting from geometrical inaccuracies, poor setup or changes in the flow field can be further investigated; however these are neglected during the error propagation calculations of these measurements.

Remember that during the labs:

- Before turning any measurement device on, or in general during the lab, make sure that safe working conditions are ensured. The other participants have to be warned of the starting of the machines and of any changes that could endanger the members of the lab.
- The atmospheric pressure and room temperature should be recorded before and after every measurement.
- The measurement units and other important factors (e.g. data sampling frequency, date of calibration) of every recorded value of the applied measurement devices should be recorded.
- Type and construction number of the applied measuring instrument should be included in the final report.
- Checking and harmonizing of the units of the recorded values with those used in further calculations.
- Manometers should be zeroed and calibrated.
- The measurement taps should be carefully connected to the correct pressure ports of the instrument.
- If inlet or outlet tubes are to be assembled with fans, connections should be airtight, as escaping/entering air can significantly modify the measurement results.
- The students should consult with their instructor before submitting the report.

References

- [1] Gruber és szerzőtársai: Ventilátorok, Műszaki Könyvkiadó, Budapest, 1978.
- [2] Lajos Tamás: Az áramlástan alapjai; Műegyetemi kiadó, 2004; Jegyzet azonosító: 45072.
- [3] Manual of the EMB-001 digital pressure meter (www.ara.bme.hu)
- [4] Formal and content requirements of the report (www.ara.bme.hu)
- [5] Guide for error propagation calculations(www.ara.bme.hu)